



**Best Management Practices for Forestry:
Protecting New Hampshire's
Water Quality**



UNIVERSITY of NEW HAMPSHIRE
COOPERATIVE EXTENSION

ACKNOWLEDGEMENTS

This document was adapted with permission from the Maine Department of Conservation's Maine Forest Service publication, "Best Management Practices for Forestry: Protecting Maine's Water Quality". Editor for this document is Sarah Smith, UNH Cooperative Extension with assistance from:

JB Cullen, NH Division of Forests and Lands
 Sandy Crystall, NH Department of Environmental Services
 Vanessa Burns, NH Department of Environmental Services
 Linda Magoon, NH Department of Environmental Services
 Hunter Carbee, NH Timberland Owners Association,
 NH Timber Harvesting Council

The original Maine document was developed by the Maine Forest Service with assistance from FORAT (Forest Advisory Team).

Members of FORAT's BMP Manual Sub-Group include:

- Morten Moesswilde, Maine Forest Service
- Roger Ryder, Maine Forest Service
- Pat Sirois, Professional Logging Contractors of Maine
- Jack Frost, Forests for the Future
- Steve Gettle, MeadWestvaco
- Andy Whitman, Manomet Center for Conservation Science
- Dave Welsch, USDA Forest Service
- Andy Egan, University of Maine, Department of Forest

Management

PROJECT MANAGERS: Jim Blanck, Maine Forest Service;
 Brian Kent, Kent Associates Planning and Design; Gardiner,
 Maine

LEAD AUTHOR: Morten Moesswilde, Maine Forest Service

EDITOR: Alison Truesdale, LandForms; Brunswick, Maine

ILLUSTRATIONS: Brian Kent

GRAPHIC DESIGN: Mahan Graphics, Bath, Maine

FIELD ADVISORS: Michael St. Peter and Yves Levesque,
 Certified Logger Program

PHOTOS: Brian Kent; Michael St. Peter; Dave Welsch; Steve Gettle;
 Andy Whitman; Maine Forest Service, various UNHCE.

Funding for the printing of this document was provided by:
 UNH Cooperative Extension, USDA, Forest Service, State and
 Private Forestry, NH Sustainable Forestry Committee

ACKNOWLEDGEMENTS i

SECTION 1. INTRODUCTION.....iv

 What This Handbook Is.....1

 What This Handbook Is Not1

 How to Use This Manual.....2

 How BMPs Protect Water Quality3

KEY ISSUE: Water Movement4

 How Harvesting Affects Water Quality9

SECTION 2. FUNDAMENTAL BMPs12

 1. Define Objectives and Responsibilities13

 2. Pre-Harvest Planning14

 3. Anticipate Site Conditions17

 4. Control Water Flow18

 5. Minimize and Stabilize Exposed Soil19

 6. Protect the Integrity of Waterbodies19

 7. Handle Hazardous Materials Safely20

KEY ISSUE: Filter Areas21

KEY ISSUE: Stabilization24

SECTION 3. BMPs FOR EVERY STAGE OF THE HARVEST31

Stream Crossings32

 Plan Ahead.....35

KEY ISSUE: Fish Passage40

 Build it Right42

KEY ISSUE: How to Size and Install

Bridges and Culverts45

 Maintain It50

 Close it Out Correctly.....51

Wetland Crossings.....52
 Plan Ahead.....53
 Build it Right54
 Maintain It57
 Close it Out Correctly.....57
Truck Roads58
 Plan Ahead.....60
 Build it Right64
KEY ISSUE: Controlling the Water66
 Maintain It70
 Close it Out Correctly.....71
Log Landings72
 Plan Ahead.....73
 Build it Right75
 Maintain It76
 Close it out Correctly77
Trails and Harvesting.....78
 Plan Ahead.....79
 Build it Right82
KEY ISSUE: Water Diversions83
 Harvest It Right85
 Maintain It86
 Close it Out Correctly.....87
Hazardous Materials88
 Fuels, Oil, and Coolants89
 Temporary Sand and Salt Storage Areas90
 Herbicide and Pesticide Use91

SECTION 4. FOR MORE INFORMATION92
 Sources of Technical Assistance92
 ReferencesInside Back Cover

SECTION 1 INTRODUCTION

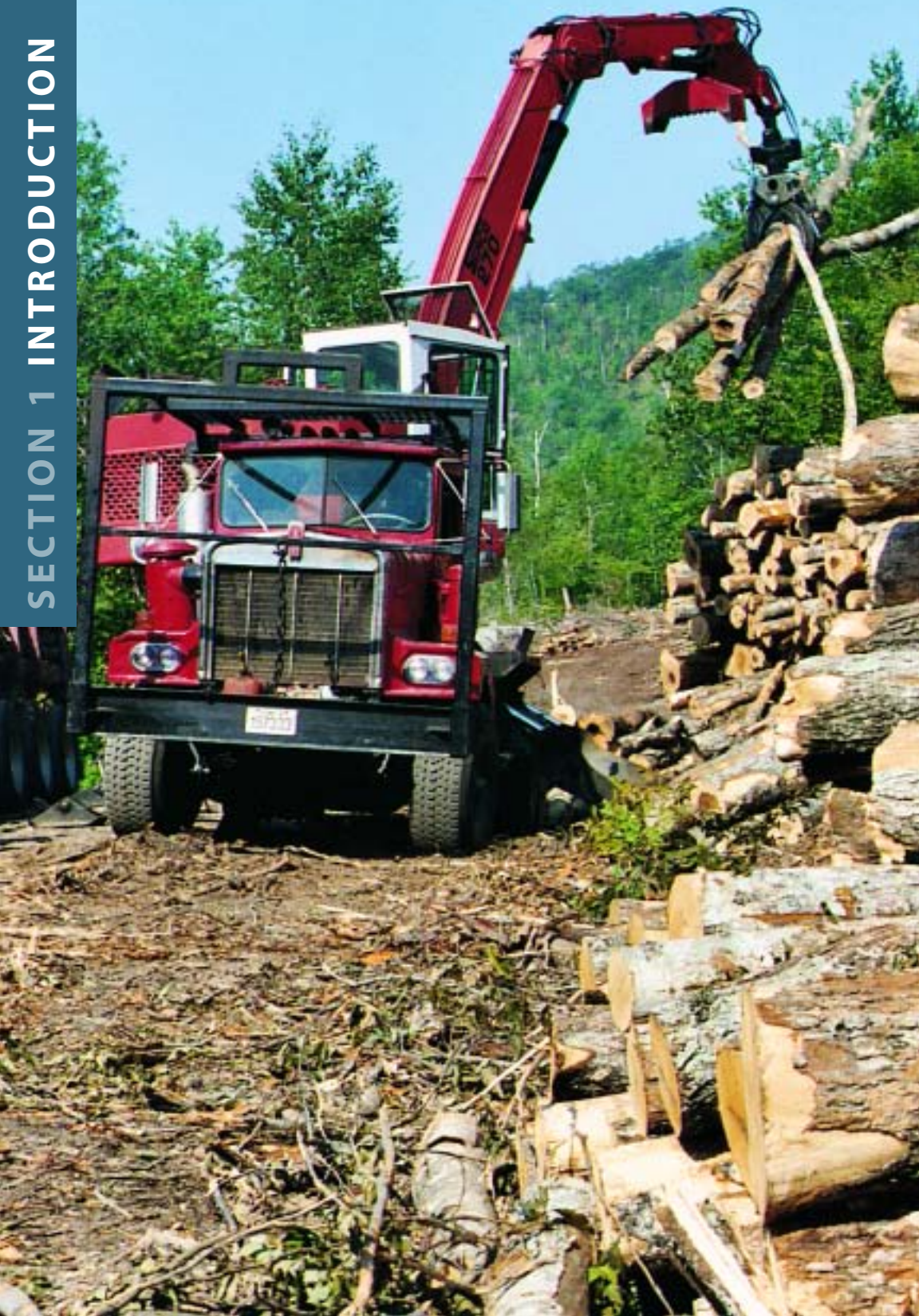

INTRODUCTION

WHAT THIS HANDBOOK IS

This handbook describes Best Management Practices, or BMPs, for protecting water quality during forest harvests. The BMPs include a wide range of recommended techniques that can be used before, during, and after logging operations. Loggers, foresters, and scientists from New Hampshire and other states have developed these techniques from their own practical experience and research.

This handbook is for woodlot owners, loggers, foresters, and others involved in harvest operations. The handbook will help you understand, identify, design, and implement water quality protection measures while meeting other harvest objectives.

This book will help you to:

- understand how BMPs work. It is more effective, cheaper, and easier to prevent pollution than to fix problems after they occur. When you understand the principles behind BMP techniques, you will be able to anticipate and prevent problems before they end up costing you time and money.
- decide which BMPs to use. Harvest sites can vary significantly, and different techniques are appropriate to different sites. By applying BMP principles, you will be able to use your own judgment and this handbook to select the most appropriate and effective BMPs for a particular site.

WHAT THIS HANDBOOK IS NOT

BMPs may not be the same as regulations. Best Management Practices are procedures that, when used appropriately, will result in the greatest protection of the environment over the course of the operation. Regulations describe required, minimally acceptable practices. BMPs are mandatory in some situations; others may be voluntary, depending on the site. If the forestry management or harvesting activities involve impacts to wetlands or surface waters (by traveling across them), BMPs are mandatory and a NH DES Forestry Notification may be required.

This handbook is not a complete how-to manual for installing BMPs. Please see “Section 4: For More Information” for titles of other documents that provide technical details on BMP installation.



This handbook focuses on water quality BMPs. There are BMPs that protect wildlife habitat, soil integrity and productivity, aesthetics, and other aspects of the forests. Although these values are important, they are not the primary focus of this manual.

HOW TO USE THIS MANUAL

In order to decide how and when to use BMPs, it's important to understand how they work to protect water quality. "Section 1: What is Water Quality?" explains different characteristics of water quality, how harvesting practices can affect them, and where it is most critical to use BMPs.

"Section 2: Fundamental BMPs" discusses fundamental BMP principles and key steps toward the overall goal of protecting water quality. These principles give you an overview of the most important things to keep in mind before, during, and after a harvest.

"Section 3: BMPs for Every Stage" lists specific BMPs for stream crossings, truck roads, log landings, skid trails, and harvesting areas. Under each of these headings is a discussion of the planning, construction, maintenance, and closeout BMPs applicable to that topic.

Throughout the manual, you will also find  signs that will alert you to potential legal requirements.  signs will point out important topics that shouldn't be overlooked. Each section is color-coded on the edge of the page to make it easier for you to find information about a specific topic.



HOW BMPs PROTECT WATER QUALITY

WHAT IS WATER QUALITY?

Forest areas in and around waterbodies are complex systems and provide habitat for a wide range of plants and animals. These forest areas, and the waterbodies in them, are the setting for different processes that provide food, water, shelter, breeding space, and other needs. For our purposes, “water quality” refers to the characteristics of water in nature that support life. These include the natural chemical, physical, and biological aspects of streams, rivers, ponds, lakes, and wetlands. The chemical properties of water include pH, dissolved oxygen, nutrients, and the presence of chemical pollutants. The physical properties of water include such things as turbidity (how clear or cloudy the water is), and temperature. In addition, the physical characteristics and natural processes of waterbodies are important aspects of water quality. Examples include stable channels, the transport of nutrients, the volume and speed of the water, the streambed material, and sticks and logs that have fallen into streams naturally.

Forest streams, lakes, and wetlands typically have excellent water quality. Forestry operations that use best management practices can protect these waterbodies’ natural ability to support life. By preventing stream sedimentation, such operations can maintain streambed properties and the clean water that allows fish—and the aquatic insects they depend on—to feed and spawn. Leaving trees that shade and provide leaf litter to waterbodies limits changes in water temperature and chemical characteristics that could reduce the ability of some species to survive and reproduce. These are just the most commonly understood examples of how maintaining the properties of water in forests can protect aquatic habitats.

Although water quality is a complex subject, BMPs are intended as relatively simple, practical steps that protect water quality. Most BMPs in this manual address turbidity by keeping sediment out of streams. Several other BMPs preserve the physical integrity of waterbodies and their natural processes. If these issues are addressed, most other aspects of water quality will be protected, too.

KEY ISSUE

Water Movement

New Hampshire has hundreds of lakes and ponds, large areas of forested and non-forested wetland, and thousands of miles of streams and rivers. All these forest waterbodies, and the areas that drain to them, are connected by moving water. Most of the water in the forest comes from rain or snowmelt which is either absorbed into the soil, flows over the ground, or enters stream channels, flowing downhill.

WATERSHED

A **watershed** is all the land and waterbodies from which water drains to a given point. You can define a watershed for an entire lake, for a stream at a crossing site, or for a river where it reaches the ocean. Watersheds range in size from just a few acres (for a small stream), to thousands of acres (for a large river). All land is part of some watershed.

It is crucial to understand where water is coming from and draining to in the watershed where logging is planned. The amount of cutting or road construction at higher elevations can affect the amount and timing of runoff at lower elevations within the same watershed. When you know where, when, and how much water flows in the harvest area, you will be able to determine the best locations for roads and trails, the size of any crossing and what types of BMPs you will need to control water movement.

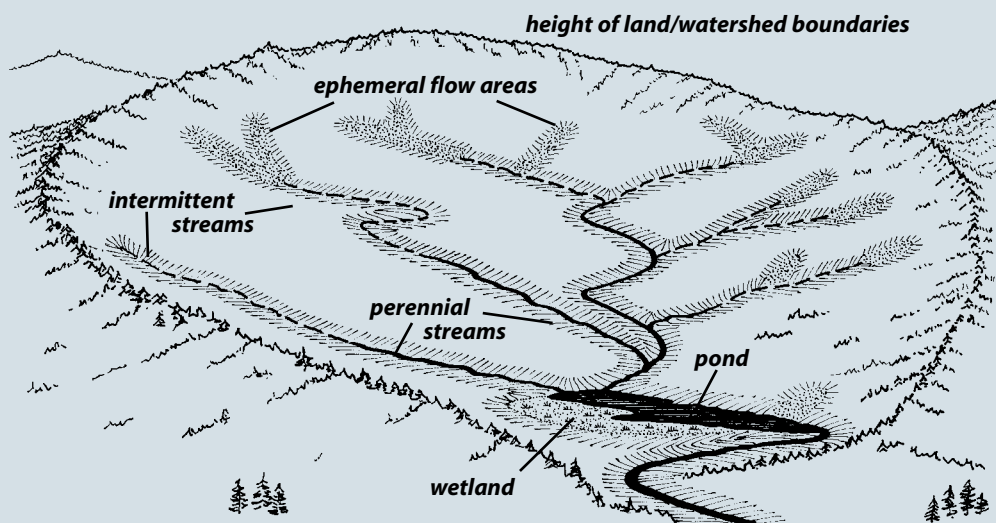

The watershed of a pond.

In this manual, “waterbodies” includes streams, rivers, lakes, ponds, and wetlands, as well as coastal areas. These BMPs are primarily for those areas where water is at or near the surface (streams, lakes, or wetlands), and where runoff can move directly into surface waterbodies. These waterbodies and related areas are defined and illustrated below.

EPHEMERAL FLOW AREAS

Ephemeral flow areas are small drainage areas that flow into streams, but have no defined, continuous channel. Examples are low-lying depressions, or swales with an intact forest floor. Soils in these areas may quickly become saturated during rainy periods, storms, or snowmelt. Surface water flows in these low areas over saturated soil without forming a channel. Water from ephemeral flow areas may carry sediment or other materials directly into streams. Ephemeral flow areas change in size in response to the soil and weather conditions, and are the proximate source of much of the water that enters small streams. Many ephemeral flow areas are wetlands.



Ephemeral flow areas are small drainages, with no defined channel, where water flows into streams during wet periods.

STREAMS

Streams are natural water channels that:

- may flow year-round or only part of the year,
- have a defined channel and banks,
- are relatively continuous and connected with larger surface waters, and
- have a streambed where flowing water has exposed the mineral bottom of soil, sand, gravel, ledge, or rock.

Forest streams in New Hampshire vary widely in how much water they carry, how steep they are, the shape of the streambed or channel, how much area they drain, and when they flow. **Perennial streams** generally flow year-round and range from small brooks to large rivers; **intermittent streams** flow only a few months of the year, or during wet seasons.



Streams can vary widely, but all have a defined, continuous channel, a streambed with exposed soil, and carry water at least part of the year.

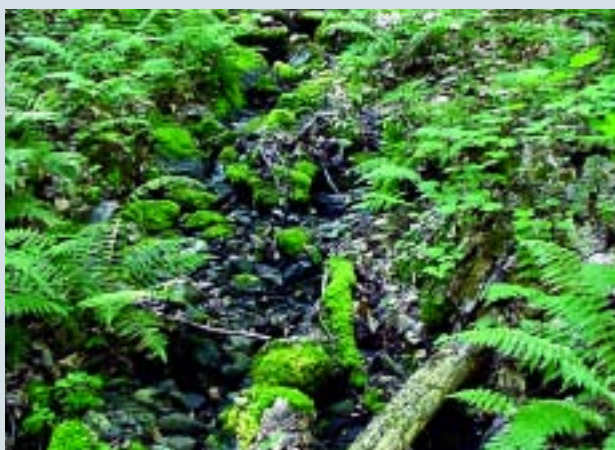

The **normal high water mark** is the place on the stream bank where the highest water levels typically occur, often during spring runoff. You can identify it from features like undercutting of the bank; a change in the type of vegetation; exposed roots that do not penetrate beyond a certain level; root scars; and water stains on rocks, stems, roots, or other vegetation.



One indication of the normal high water mark is undercutting or scouring of the bank.

WETLANDS

Wetlands are areas where soils are saturated or flooded at least part of the year, and where water-loving plants are often found. Wetland soils usually have developed special characteristics, and have water at or near the surface.

Forested wetlands are dominated (or potentially dominated) by trees taller than 20 feet. Forested wetlands vary widely in their characteristics, often have relatively little water directly at the surface, and have indistinct borders. They may require considerable expertise to identify. Forested wetlands are often managed for timber, with roads and trails crossing them.

Bogs (non-forested or open wetlands) are not dominated by trees, though they may have some scattered trees, mostly less than 20 feet tall. They have water at or near the surface at least part of the year, and may have a more or less distinct border defined by the surrounding forest. The high water and organic content of wetland soils make them considerably weaker than upland soils and difficult to work in. The NHDES Forestry Notification form cannot be used to cross a bog (or marsh). Contact NHDES for permitting information.

Vernal pools are a type of wetland, typically forested, which provide specialized habitat and deserve special attention. Separate guidelines for identifying vernal pool habitat are available from the NH Fish & Game Department, Non-game and Endangered Species Program.



forested wetlands



bogs



vernal pools

HOW HARVESTING AFFECTS WATER QUALITY

HOW HARVESTING CHANGES WATER FLOW

Forest harvests can directly impact water quality by affecting how water flows through an area. In particular, constructing roads, trails, landings, or drainage systems can:

- **reduce the soil's absorbency.**

This can occur any time the forest floor is disturbed, removed, compacted, or otherwise damaged.

- **increase soil erosion.**

The opportunity for soil to be carried away by runoff increases greatly when mineral soil is exposed or fill is used.

- **divert water flows.**

Roads and trails can block or intercept water moving over or through the soil. The more water that accumulates, the greater the chance that it will form a channel and start eroding soil. Sometimes harvesting can cause streams to erode a new channel by blocking the stream's flow with logs or debris.

- **concentrate water flows.**

Roads, trails, landings, and their associated drainage structures can collect and funnel runoff, creating rills or gullies. In these situations, water erodes and transports exposed soil in its path.

- **diminish the benefits of vegetation next to waterbodies.**

Harvesting may reduce shade on the water's surface, reduce the amount of natural woody debris, or eliminate leaf litter that is an important food source for aquatic life. In addition, timber harvests that remove a significant percentage of the trees in a watershed can increase the amount of water moving through the soil into streams, and in some instances, increase flooding.

Usually, it is impossible to avoid disturbing some soil or concentrating some flowing water during a harvest. The important point to remember is to avoid these disturbances as much as possible, and to use BMPs to prevent them from resulting in sedimentation or erosion.

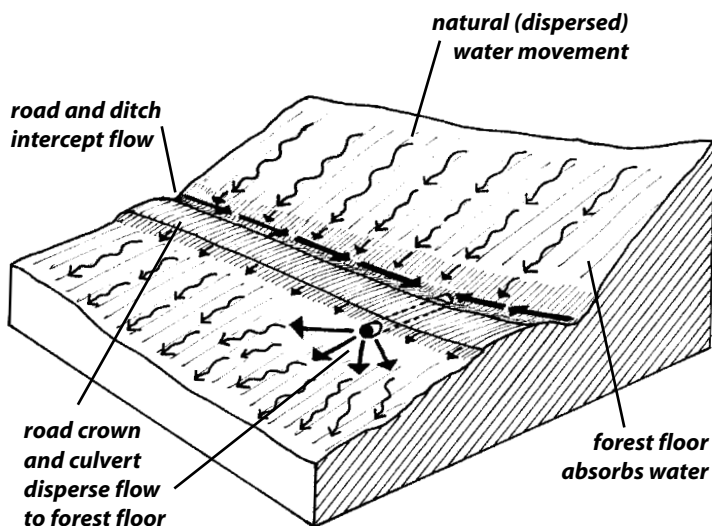

Harvesting operations intercept natural water movement and concentrate it in ditches or on the road/trail surface.

DRAINAGE SYSTEM OR STRUCTURES are all the techniques used to get water off the road, trails, or landing. These can include the road crown, ditches, turnouts, cross-drainage culverts, water bars, etc.

WHAT DO BMPs DO?

BMPs are designed to mimic or protect the natural functions of forests. BMPs can absorb or disperse runoff, retain soil nutrients, filter sediment, prevent large changes in water temperature, and contribute organic material to surface waters.

- **BMPs minimize the risk of sediment and other pollutants getting into waterbodies.** Sediment—soil, dirt, silt, sand, mud—is the primary type of water pollution from forestry operations.
- **BMPs maintain the natural flow of water in streams and wetlands.** They avoid blockages, keep water flowing in its natural path, and prevent damage to the streambed and banks.
- **BMPs protect shoreland vegetation.** Some practices simply preserve enough of the forest so that it continues to function normally: shading the waterbody and stabilizing water temperatures, maintaining the soil's natural functions, and contributing organic matter that serves as habitat and a food source to aquatic plants and animals.
- **BMPs protect the habitat of aquatic organisms.**

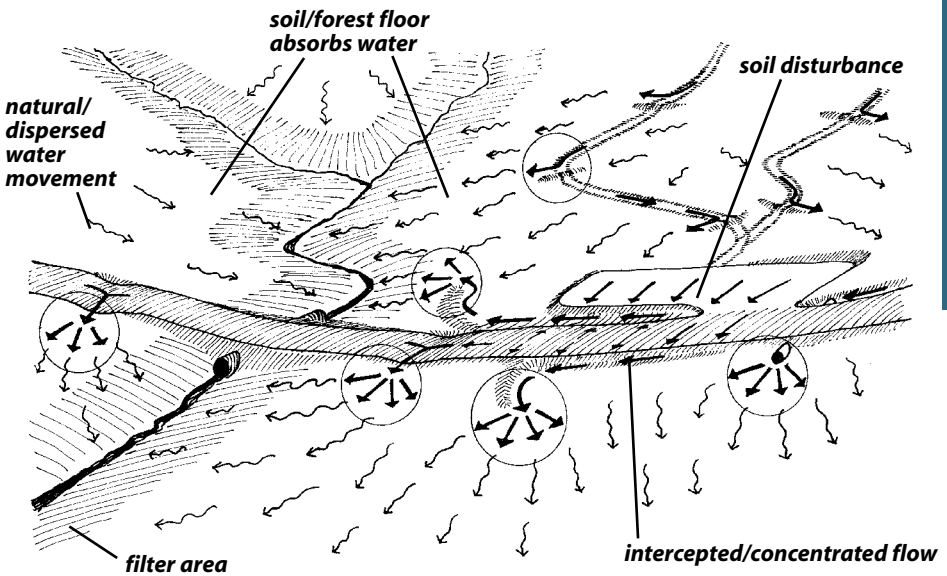

One way BMPs minimize impacts to water quality is by dispersing concentrated water flow. Circles indicate where BMPs disperse flow to the undisturbed forest floor.

SECTION 2 FUNDAMENTAL BMPs



FUNDAMENTAL BMPs

Most BMP techniques are based on a few basic principles. This section provides an overview of these fundamental BMPs and how they protect water quality.



Understanding these principles will enable you to select or adapt the BMPs that are the most appropriate and effective. Think of these principles as goals. Any single practice or combination of practices that effectively achieves one or more of these key goals could be considered an appropriate BMP.

1. DEFINE OBJECTIVES AND RESPONSIBILITIES

- Determine the harvest objectives with the landowner, forester, and logger.** The first step in planning, prior to beginning work, is to communicate with everyone involved the harvest objectives. Discuss what's going to be cut, where, and the desired condition of the remaining forest.
- Decide who is responsible for BMPs.** You will want to agree in advance (and in a written contract) who is responsible for implementing the BMPs, including deciding when to operate, locating streams, laying out the operation, and planning and maintaining the BMPs.



Know the laws! Landowners, foresters, and loggers should determine what laws apply on a particular job. This manual does not replace legal standards, and reading it is not a substitute for knowing legal restrictions in your situation.

- Find out what legal requirements apply to waterbodies and wetlands in the harvest area.** The basic legal requirement in New Hampshire is to keep pollution—including mud, silt, rock, soil, brush, or chemicals—out of the water and wetlands. When working near waterbodies, find out what town, state, or federal standards apply, and when permits are needed. If you will need to cross a wetland that is not frozen (or dry enough that no ruts will be created) or cross a stream, you will need a wetland permit or forestry notification form NHDES.

2. PRE-HARVEST PLANNING

Pre-harvest planning is good business practice and avoids many problems. Planning will help reduce costs, make the job more efficient, protect roads and trails that will stay in place after the job, leave the job looking better, *and* protect water quality.

- Determine the harvest area limits and property boundaries on the ground. Know whose responsibility it is to identify the property boundaries correctly.** While not essential to protect water quality, locating property boundaries is common sense and good planning. There may be survey pins, blazes, wire fences, or stone walls that mark boundaries or property corners. Forest type maps, soil or topographic maps, or aerial photos help, too.

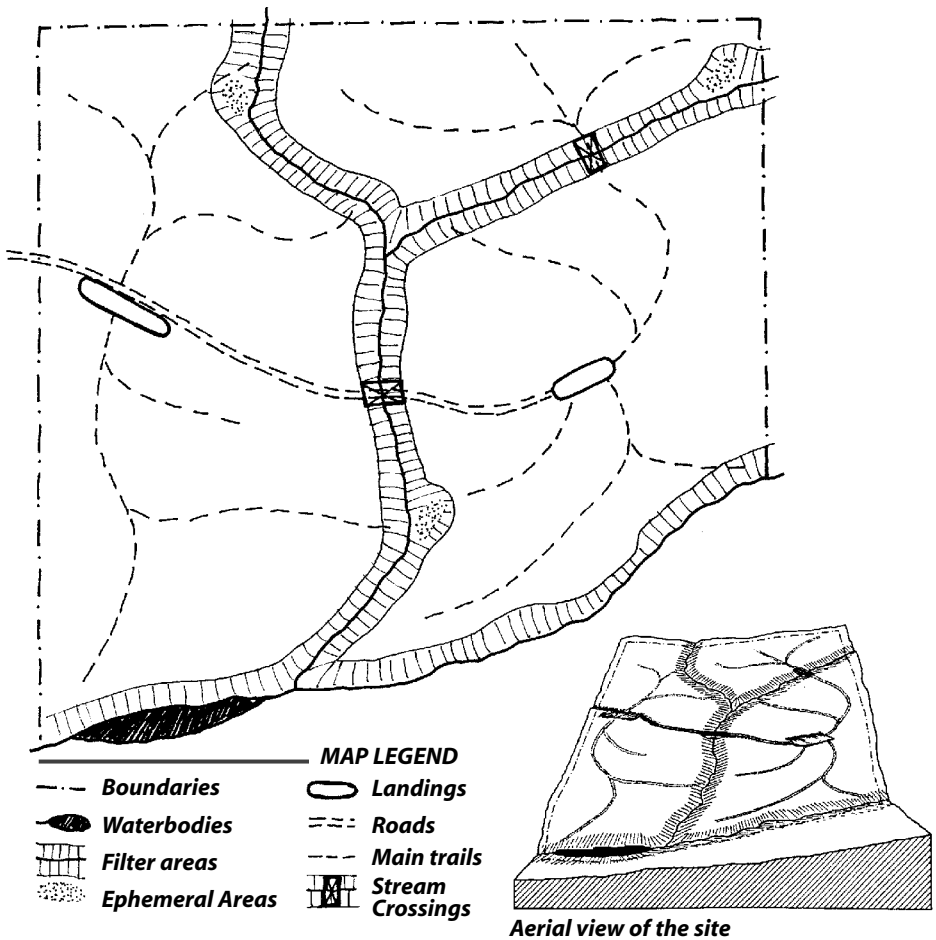

Example of map showing planning and layout on large lot.



When in doubt, stop! Get more information or professional advice. Contact the Department of Resources & Economic Development, Division of Forests and Lands at (603) 271-2214, or www.nh.gov/dred/divisions/forestandlands/ for answers and referrals to professionals who can help.

- **Identify streams, lakes or ponds, wetlands, and other features on maps and on the ground.** Maps and aerial photographs can help identify features like waterbodies, steep slopes, poorly drained soils, or sensitive natural resources. Walking the property to locate important features on the ground is essential. If possible, do your planning on bare ground in wet seasons when surface water is visible.
- **Identify the areas where you need BMPs.** Forest harvesting BMPs are most critical in and immediately next to waterbodies including intermittent and perennial streams, lakes or ponds, wetlands and coastal areas—wherever direct impacts to surface water may occur. You may also need to use BMPs in other areas of the watershed where flowing water could be substantially altered or carry sediment into these waterbodies.
- **Lay out the harvest operation on the ground.** Harvest planning includes determining where operational features such as roads, stream crossings, landings, cut-and-fill areas, main skid trails, and particular BMPs will be needed. While on-site, make sure everyone involved in the harvest operation is aware of the layout—especially roads, skid trails, and filter areas next to waterbodies.



There is no substitute for laying out the harvest operation on the ground.

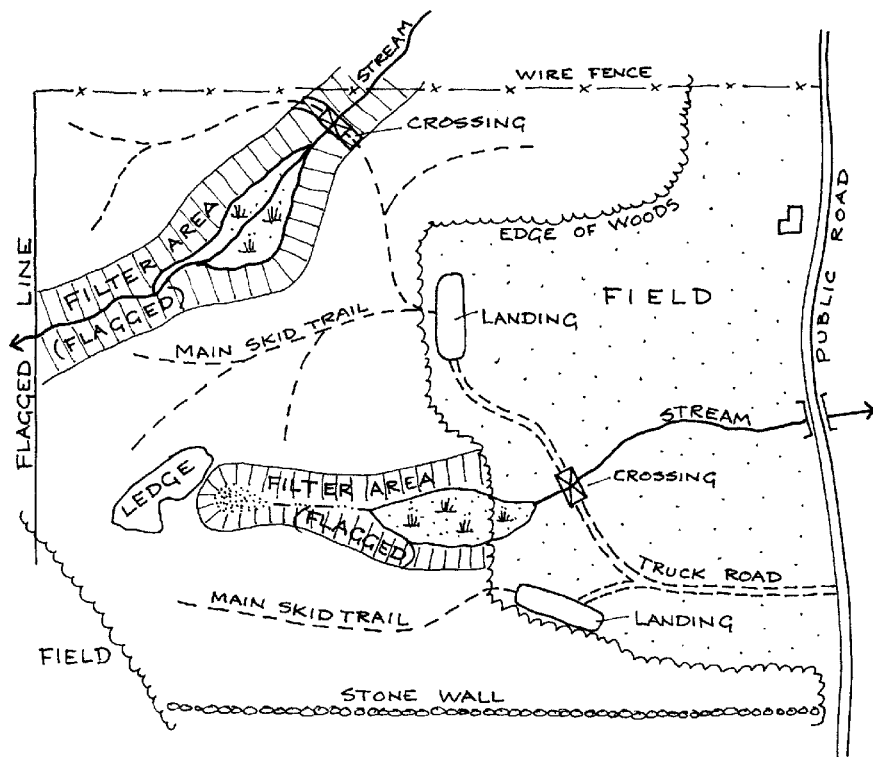

Example of map showing planning and layout on small lot.

- Choose BMPs that are appropriate to the site conditions.**
 Most sedimentation occurs during short periods of heavy rain or snowmelt. How much rain falls during a storm, how much water streams carry, how stable the soils are, and what types of vegetation are present are all conditions that vary. BMPs that are sited, designed, and installed to anticipate adverse conditions work best.
- Decide on BMPs for the entire harvest area and for closeout before beginning work.** BMP systems need not be complicated, but they require planning across the entire harvest area and over the entire duration of the operation, including closeout. Applying BMPs in one location can sometimes solve problems elsewhere on the site, or prevent problems after the operation is complete. When you understand the natural drainage system in the watershed, often you can use a combination of simple BMPs that are more effective—and cheaper—than more complex or expensive techniques.

- **Consider the needs of future operations on the same property.** Will roads, trails and landings be used again in five years, 15 years, or longer? Are there other areas of the property that can be accessed using the same roads? If you need to access the lot in the future, plan roads and trails accordingly. Otherwise, consider restricting vehicle access after the harvest. Because of the possibility of extreme weather conditions, it is important to design and close out roads properly. Identify which structures—such as culverts—will be left in place, and which will be removed. Considering the future can avoid problems and costly solutions.

3. ANTICIPATE SITE CONDITIONS

- **Time operations appropriately.** Harvesting under frozen, snow-covered, or dry conditions can minimize the need for additional BMPs. At the same time, a range of BMPs that are appropriately chosen, installed, and maintained can extend the harvest season. Use extra caution during fall and spring when streams are high and the ground is typically wetter—you may need to use additional BMPs to control the larger volume of water.



Impacts to surface water or wetlands require some type of authorization or approval from the NHDES Wetlands Bureau.



Site conditions both during and after the harvest are likely to change.

- **Determine whether previous operations in the harvest area created conditions that are impacting—or could impact—water quality.** Old roads, log landings, and skid trails can be reused or upgraded. However, in some situations, avoiding or retiring them is a better choice. Using old roads, landings, and trails may be cheaper in the short run, but may be more costly to fix or maintain later. Pre-existing conditions may also influence your choice of BMPs.
- **Plan to monitor, maintain, and adjust BMPs as needed, especially to deal with seasonal or weather-related changes.** After installation, most BMPs require maintenance or modification. Conditions—such as the amount of water flowing in streams, soil moisture, or the depth of frost—can change quickly, even with one storm. Take into account how conditions may change, and maintain or install additional BMPs as needed. Determine who will be responsible for this work. In many instances, the landowner will want to periodically check and maintain BMPs that have been installed after harvesting is done. This often prevents washouts and a loss of access while protecting water quality at the same time.

4. CONTROL WATER FLOW

- **Understand how water moves within and around the harvest area, and decide how water flow will be controlled.** Concentrated flows of water on roads, skid trails, landings, and in drainage systems develop more force and a greater ability to erode soil and carry sediment. It is easiest and most effective to control small volumes of water, before they converge and accumulate into concentrated flows.
- **Slow down runoff and spread it out.** Many BMPs work by directing small amounts of water into areas of undisturbed forest floor where it can be absorbed.



Properly sized ditches capture and slow down runoff.

- **Protect the natural movement of water through wetlands.**

Wetlands play an important role in the environment by storing water in wet periods and slowly releasing it back into the surrounding ground and streams. Logging roads and trail crossings can affect the flow of water within or through a wetland. This changes how much water the wetland stores, the degree of flooding that occurs, and the rate at which water leaves the wetland. Such impacts can affect the health of the wetland and waterbodies downstream.

5. MINIMIZE AND STABILIZE EXPOSED SOIL

Limiting soil disturbance and stabilizing areas where mineral soil is exposed are among the most important BMPs for preventing erosion. These practices are most critical in and around filter areas—forest areas bordering waterbodies. A detailed discussion of filter areas, how best to work in them, and soil stabilization starts on page 21. Generally speaking, there are two major objectives:

- **Minimize disturbance of the forest floor, especially in filter areas.** The forest floor absorbs water and filters out sediment and other pollutants. Exposed soil, on the other hand, can erode very rapidly. Most of the sediment that ends up in streams near managed forests comes from exposed soil on roads, landings, and skid trails. Know where the filter areas are and how to protect their capacity to absorb and filter runoff.
- **Stabilize areas of exposed soil within filter areas and in other locations where runoff has the potential to reach filter areas.** Use BMPs during or immediately after the harvest to prevent exposed soil or fill from eroding. These techniques and materials can be used near waterbodies, at stream crossings, road cut-and-fills, ditches, landings, and skid trails. In some situations, you may need to seed and/or plant vegetation in order to stabilize the soil.

6. PROTECT THE INTEGRITY OF WATERBODIES

- **Protect stream channels and banks.** Blocking or altering streams (with slash, for instance) may keep fish from swimming past the blockage. Damaged stream banks erode quickly, causing sedimentation and siltation. By protecting the physical integrity of streams, BMPs prevent fish passage issues.
- **Leave enough shoreland vegetation to maintain water quality.** BMPs maintain the benefits that nearby trees and plants provide waterbodies. Streamside vegetation shades the water, minimizing temperature changes. Live roots stabilize the banks and maintain the soil's physical and chemical properties. Trees along the banks drop leaf litter and woody debris that supply nutrients and become habitat for plants and animals in the stream. Shoreland vegetation plays an important role in maintaining water quality.

7. HANDLE HAZARDOUS MATERIALS SAFELY



For assistance with spills of hazardous materials, call the New Hampshire Department of Environmental Services:

**Monday – Friday
8:00 a.m. – 4:00 p.m.
(603) 271-3644**

**All other times call:
(603) 271-3636**

- **Be prepared for any emergency.** Keep an emergency response kit and contact information at the site for fuel, oil, or chemical spills. Remember that fertilizers, herbicides, pesticides, and road chemicals (calcium chloride, road salt, etc.) are hazardous materials, too. Know whom to call for help with unexpected erosion, accidents, or other emergencies. Having a backup plan and being prepared for unexpected and special situations can help avoid or minimize negative impacts to water quality. Industry groups, equipment suppliers, and local and state government agencies all have specialists available to help. Refer to “Section 4. For More Information” on page 92 for agency names, addresses, and telephone numbers.
- **Use and store hazardous materials properly.** The best way to avoid accidental spills of hazardous materials is to store and handle them so that the chance of these types of emergencies occurring is minimized. You’ll find several BMPs in this manual that describe how to do this, starting on page 89 in Section 3, BMPs for Every Stage.

KEY ISSUE
Filter Areas

Filter areas, broadly speaking, are forested areas bordering waterbodies that provide important functions, especially filtering sediment and debris from runoff and preventing pollutants from reaching waterbodies. Filter areas have several components.

- The **banks** of streams (or other waterbodies) protect and contain the water channel.
- The undisturbed **forest floor**—especially the leaf litter, woody debris, and organic soil layer—absorbs and filters water as it moves over and through the soil.
- **Trees and other vegetation** shade the water (minimizing changes in water temperature), stabilize the banks, and add woody debris and organic matter to the water and forest floor.

Limiting impacts to these components within a minimum distance from the waterbody (depending on slope) typically maintains these benefits and protects water quality.

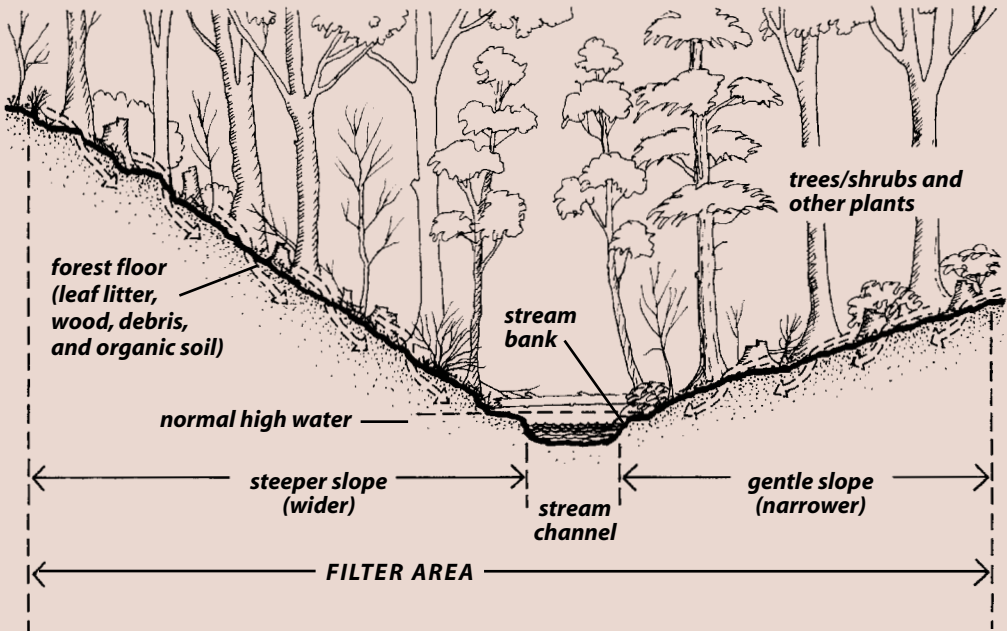

WORKING IN FILTER AREAS

Forested filter areas are not “no-harvest” zones; you can often cut within them. You may also use logging equipment in filter areas if the forest floor is protected. However, it is important that you take extra precautions within filter areas to prevent water pollution.

Note that the filter areas described here may be wider or narrower than regulatory requirements for forestry activities.

Table A
Minimum Filter Area Width

Slope (%)	Width from High Water Mark (ft)
0-10	50
20	65
30	85
40	105
50	125
60	145
70+	165

BMPs

- Determine what legal requirements you must meet when working near waterbodies.**
- Delineate filter areas next to streams, lakes and ponds, and wetlands.** Minimum recommended widths (from the normal high water mark or edge of wetland) for filter areas appear in Table A.
- Apply BMP techniques for roads, landings and skid trails (described in later sections) when working in filter areas to:**
 - minimize damage to the stream channel, stream banks and wetlands;
 - protect the forest floor next to streams and other waterbodies from disturbance;
 - disperse concentrated flows of water through the area;
 - minimize or stabilize exposed soil; and
 - retain an adequate canopy of trees and/or other vegetation.

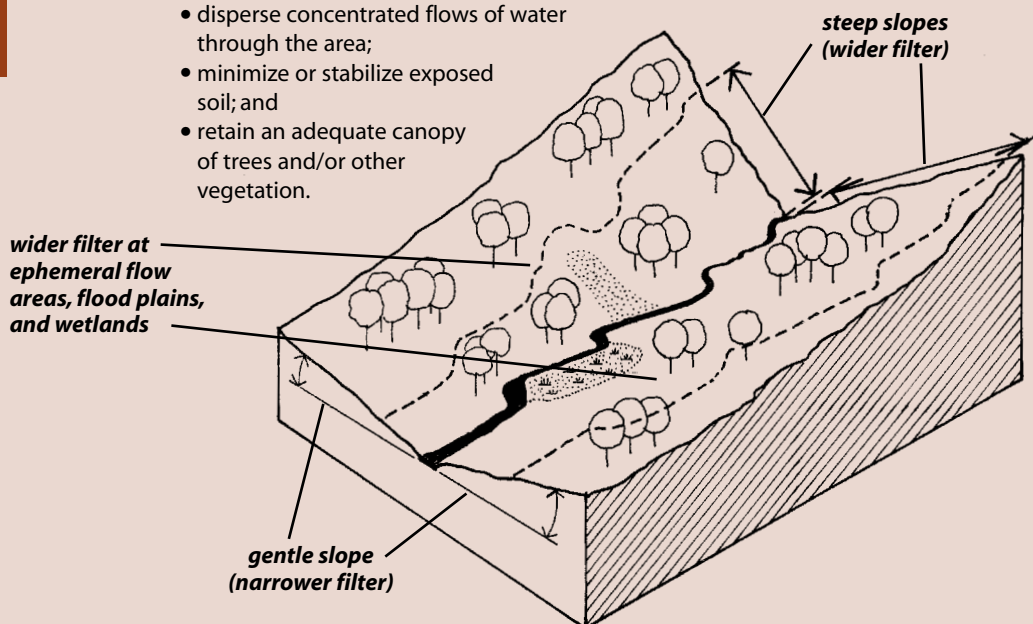

The minimum filter width varies with slope and site conditions.

- 4 Increase the width of the filter area and install more BMPs when local conditions call for it.** The recommended minimum filter area widths are based on the ability of the undisturbed forest floor to absorb water and filter sediment. The actual width needed for the filter area to be effective may be greater than the minimums listed in Table A, depending on the site conditions and planned activity. Examples of situations where it is best to designate a filter area wider than that stated in Table A include:

- **ephemeral flow areas next to waterbodies.**

Water from ephemeral flow areas may carry sediment or other materials directly into streams (especially during wetter seasons).

- **forested wetlands and floodplains next to waterbodies.** Typically, these are wetter, weaker soils. They are more likely to develop ruts and produce rapid runoff into nearby waterbodies.

- **water diversions that concentrate flow.** Culverts, ditches, and other drainage structures may increase the amount of water flowing into the filter area. They could also create a new channel through the filter area, reducing its effectiveness. In these cases, increasing the filter area width and making sure the drainage structures and BMPs are properly installed will help disperse the water.
- **some stand conditions.** Some sites may warrant wider filter areas to maintain the wind-firmness of the stand or provide adequate shade on the waterbody.



Forest harvesting operations in wetlands are subject to the Wetlands Dredge & Fill law, RSA-482-A. NH law limits forest harvesting operations near surface waterbodies 10 ac or greater in size and any fourth order or higher stream. For further info contact NH Division of Forests & Lands F&L @ 271-2214. Know which law applies to your situation.

KEY ISSUE

Stabilization

STABILIZING EXPOSED SOIL

Stabilizing exposed soil is most important where sediment can be carried to waterbodies. Different materials may be used to reduce erosion on exposed soils. Temporary materials are often ones that will rot and/or that will be replaced by natural vegetation. Permanent stabilization is provided by long-lasting, sturdy vegetation, stone or artificial materials designed to withstand the force of moving water. Often, stabilization materials are used in combination with each other, providing both immediate, temporary stabilization and permanent revegetation.

TEMPORARY MATERIALS

Hay or **straw mulch** can help minimize soil movement, and usually lasts one or two seasons, holding the soil until the natural vegetation grows back. Mulch is often used after seeding exposed soil. Hay and straw are not effective in areas of concentrated flows. Be aware that hay mulch typically contains non-native grass seed, while straw does not.

- When mulching exposed soil with hay or straw, use enough mulch to cover the soil completely or nearly completely. A common guide is approximately 90 lbs. of mulch per 1,000 square feet (or about 2 square bales for a 30 x 30 foot area). On steep slopes (greater than 4:1 or 25%) or exposed windy sites, it may be necessary to anchor the mulch with staples, netting, or twine.



Hay mulch on landing.

Brush, slash, and tops from harvesting are often readily available, and are an excellent means of stabilizing exposed soils until the area revegetates naturally. Brush typically does not need to be removed except if it falls below the normal high water mark of waterbodies.

- Use brush on trails that could erode and deliver sediment to streams. Wherever possible, put brush down before the soil becomes disturbed and the soil exposed. The more brush, the better.
- Use brush as a berm on the lower shoulder of roads running across slopes to help stabilize exposed soil and disperse water being shed off the road.
- Use brush on landings or similar high traffic areas (if it will not present a hazard to equipment).
- Use brush at the outfall of dips, water bars, and other drainage structures to help hold the soil and disperse concentrated runoff.



Harvesting during frozen winter conditions and putting slash in the skid trails are both excellent ways to limit soil disturbance.

Seeding grasses that will establish themselves quickly can help minimize erosion of exposed soil. Temporary seeding works best on slopes less than 4:1 (25%). The recommended grasses for temporary seeding include winter rye (110 lbs./acre), oats (80 lbs./acre), or annual ryegrass (40 lbs./acre). See “Seeding,” page 28, for instructions on how to sow seed.

Temporary erosion control blankets are available in rolls and are made of a wide variety of materials. Usually they are biodegradable. They are often used with grass seed to establish vegetation as the blankets rot. Erosion control blankets must be in contact with the soil to prevent water flowing between the blanket and the soil. On slopes greater than 4:1, blankets may need to be anchored with staples or by other means. Blankets work best in ditch and swale sections (where there is concentrated runoff) when the slopes are gentle.

PERMANENT MATERIALS

Wood chips, waste wood, or bark mulch may last several seasons, depending on the material and its depth. Occasionally, these materials are combined with soil in an erosion control mix. Spread the material to a depth of 2–6 inches, primarily on slopes less than 4:1 (25%). Wood chips, waste wood, and bark mulch are not allowed in streams or where they may be subject to erosion.

Permanent erosion control blankets are usually made of synthetic materials and are used in high-flow areas such as ditches.

Gravel can provide adequate stabilization, especially on travel surfaces with low slopes and little concentrated flow. Ideally, gravel used in critical areas is screened and/or washed to remove the fines.

Riprap or cobbles are larger stones used to stabilize ditches, heavily traveled areas, and areas of high flow. They are also used to armor steep slopes (up to 1.5:1 or 67%) and culvert inlets and outlets. You can use riprap in combination with erosion control blankets to prevent flowing water from undercutting steep slopes. Use very large stone in combination with smaller cobbles and/or blankets.

Permanent vegetation or revegetation is commonly used to permanently stabilize disturbed areas. Permanent vegetation may include grasses, shrubs, and/or trees. Seeding is recommended on exposed soils within filter areas, at waterbody crossings, and at similar critical sites that are not stabilized by other means. Most other areas will reseed naturally within two years, provided BMPs have been used to control the water flow.



Hay mulch holds exposed soil while grass becomes established.

Wide varieties of seed mixtures for permanent revegetation are available. Usually, they contain combinations of creeping red fescue, annual ryegrass, tall fescue, flatpea, switchgrass, bluestem, deertongue, and other species. Native, non-invasive grass species are preferable if they are available and affordable. Commercially available “Conservation Mix” is often appropriate. A typical mix consists of: creeping red fescue (40%); annual ryegrass (31%); Dutch white clover (20%); birdsfoot trefoil (5%); and hairy vetch (4%). Select a seed mixture based on:

- the site conditions;
- how quickly the soil needs to be stabilized to avoid sedimentation;
- the time of year and predictable weather conditions;
- the soil’s moisture and fertility; and
- shade conditions.



Permanent material placed in wetlands surface waters or other jurisdictional areas requires a permit from the NHDES Wetlands Bureau.

SEEDING

Whether you are seeding for temporary or permanent vegetation, the sowing process is the same.

- Prepare the seedbed (if necessary) by raking, grading, removing debris, and/or smoothing the exposed topsoil.
- Apply the seed mix immediately after preparing the seedbed, at the supplier's recommended rate (generally from 20–50 pounds per acre) by hand, seed spreader, or hydro-seeder.
- If possible, apply seed in the spring, fall, or after rain to help ensure germination.
- Consider liming and fertilizing the site before seeding, based on soil conditions, or if it is recommended by the seed supplier. Fertilizer-coated seed mixtures may also be available. A few seed types, such as legumes, require inoculants (available from the supplier) in order to become established.
- On critical areas (near waterbodies), dry soils, highly erodible sites, or sites seeded during the summer, mulch the seeded area with hay or straw.
- Do not allow vehicles or heavy foot traffic in areas that have been seeded until the cover is well established.



Fertilizer is prohibited with 25 feet of certain surface waters and restricted within 250 feet of those surface waters. Contact NHDES at (603) 271-2147 or www.des.nh.gov/cspa.

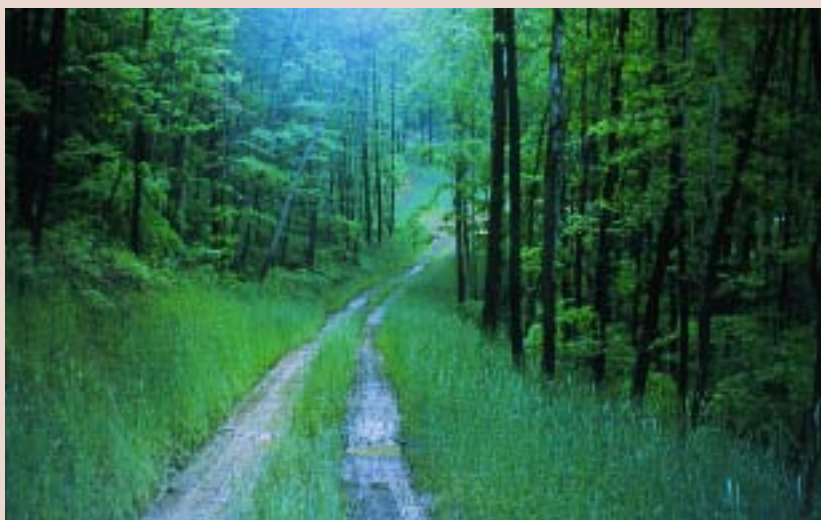

Seeding with grass seed will help stabilize exposed soil, often within a single growing season.

TEMPORARY SEDIMENT BARRIERS

Temporary sediment barriers such as hay bales and filter fences are used to trap sediment during the construction of roads, ditches, and BMPs until other measures, especially permanent vegetation, can be installed. Hay bales and silt fences are not intended as permanent structures and should be removed during closeout or after the site has stabilized.

HAY BALE INSTALLATION

- Excavate a trench 4 inches deep and the width of the bale;
- position the hay bales in a single row or stagger them, making sure there are no gaps between the bales where water could flow through;
- place the bales in the trench and stake with at least two stakes per bale; and
- backfill with soil on the uphill side to keep water from flowing underneath the bale;
- do not install hay bales in streambed.

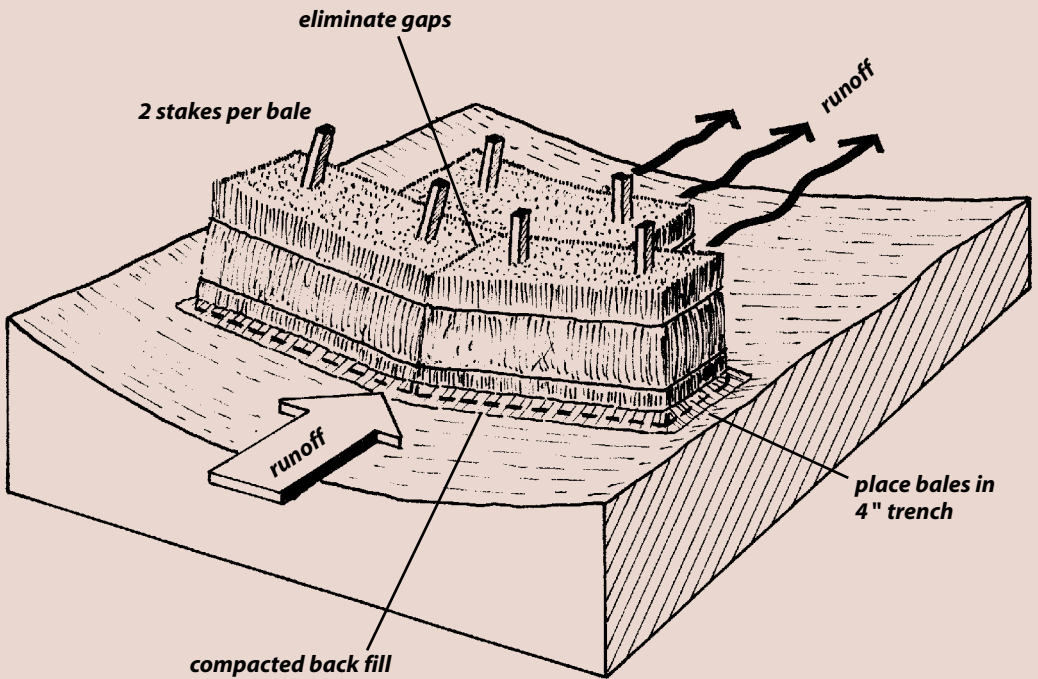

FILTER FENCE INSTALLATION

- Install a synthetic filter fence by first setting stakes at least every 3–10 feet. Three feet between stakes is needed for light fabric, while 10 feet between stakes is adequate when using extra strength fabric or a wire mesh support fence.
- Follow the manufacturer's recommendations and choose a filter fabric capable of handling the expected water flow. The fabric may be 15-36 inches high.
- Excavate a 4-inch deep trench upslope, along the line of stakes.
- Place an 8-inch skirt of fabric in the trench; staple the other side of the fabric to the stakes; then backfill and compact the soil.
- Do not install silt fence across streambed.



Hay bales and silt fences are temporary measures. Remember to remove them after the harvest, or when the site has stabilized.

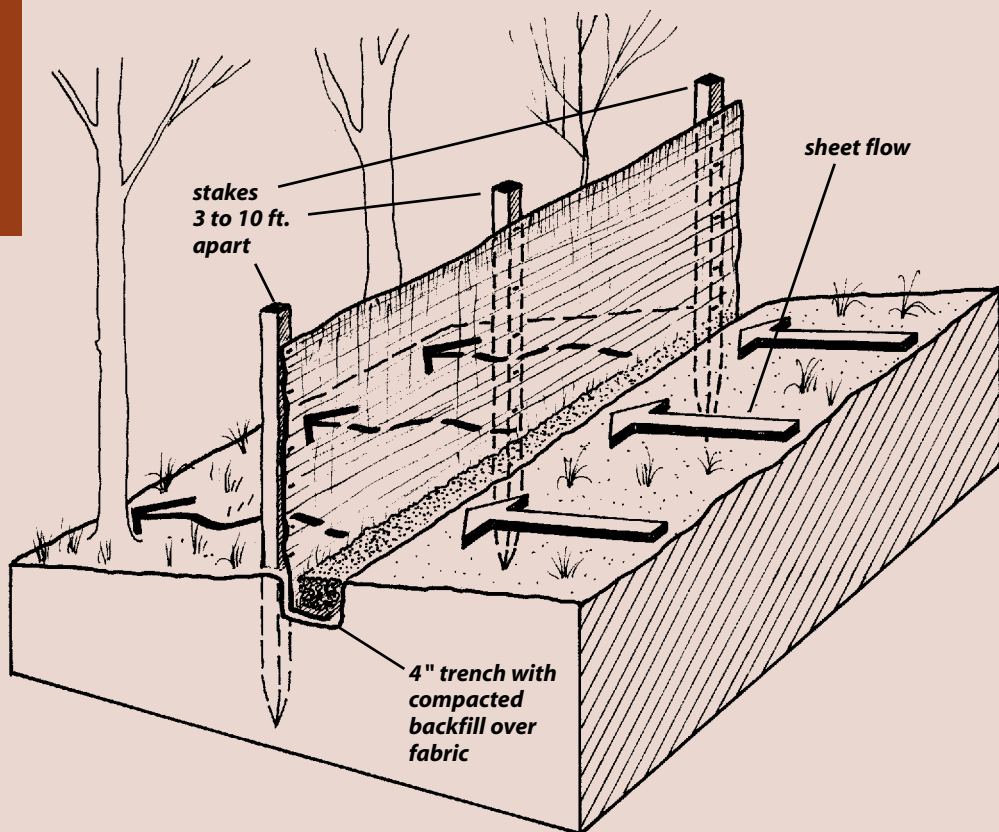

BMPs FOR EVERY STAGE OF THE HARVEST

The remaining sections of this manual cover specific Best Management Practices that are appropriate for a variety of situations or stages of a harvest operation. All are techniques that are intended as steps toward achieving one or more of the Fundamental BMPs listed in the previous section.

The specific BMPs you select in any given situation will depend on a range of factors: the site itself—including terrain, slope, soils, and location in the watershed—as well as the forest stand type, equipment, materials, and experience. The following guidelines are applicable in many situations. However, specific practices may need to be implemented in unique combinations, modified for particular circumstances or incorporate new technology or research in order to meet the objectives of the Fundamental BMPs.





HIGHEST PRIORITIES

- Minimize damage to the streambed and banks.
- Avoid altering the channel or restricting the flow of water.
- Maintain fish passage.
- Minimize and stabilize exposed soil on crossing approaches.
- Control runoff on approaches.
- Close out the crossing properly.

STREAM AND WETLAND CROSSINGS

Stream crossings can have a significant negative impact on water quality. However, these impacts can be minimized by making sure your temporary and permanent crossings are properly installed.

 **Most stream or wetland crossings require a permit or filing of a notification to the DES Wetlands Bureau.**

Stream crossings encompass the entire section of a road or skid trail as it crosses the filter area on both sides of the stream, including:

- the channel itself;
- the stream banks; and
- the road or trail approaches (at a minimum, a length equal to the recommended width of the filter area at that point).

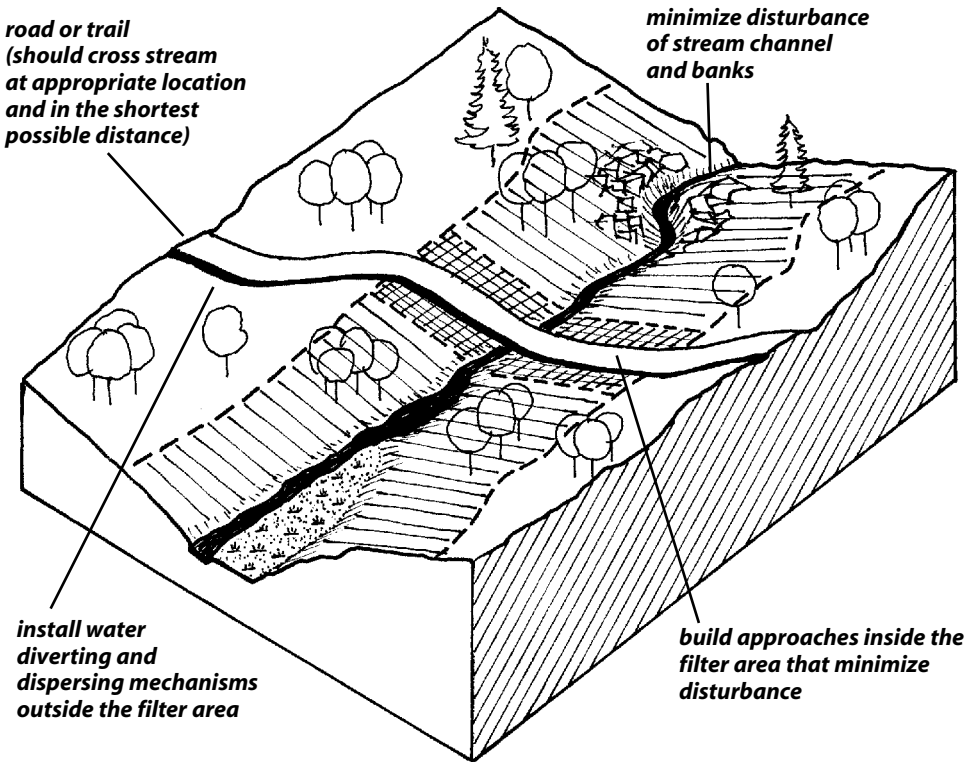

Stream crossings typically require consideration of several factors.

There are two types of crossings, temporary and permanent:

Temporary crossings are generally used by skidders, forwarders, and other yarding and felling equipment.

Permanent crossings are intended to be in place for many years. Truck road crossings, for example, are often permanent and require careful design, installation, and long-term periodic maintenance. Permanent crossings are occasionally used for skidding or forwarding, but usually only if there are other access needs for the crossing.



A temporary bridge on a winter skid trail.



A permanent bridge.

PLAN AHEAD

Plan stream crossings before road construction, trail layout, and harvesting begin.



Crossings on streams with fish may be required to allow fish passage through or underneath. See page 40 for general fish passage guidelines. Call the New Hampshire Fish and Game Department, Inland Fisheries Division for help identifying streams with fish habitat at (603) 271-2501.

BMPs

- 1 Determine if a temporary or permanent crossing is needed. Select the type of crossing that best matches the site and stream characteristics, and the need for access.** If you don't need permanent access, properly installed temporary crossings may have less of an impact on water quality.

Temporary stream crossings include:

- portable bridges,
- temporary culverts or pipe arches,
- logs or pole fords.

Use temporary structures to keep equipment out of flowing water, to prevent sediment from entering the water, and/or to protect the banks and stream bottom. Portable, removable structures such as bridges, mats (only for dry crossings), and culverts (when they are installed without additional fill) have the advantage of being reusable.



Temporary culvert crossing of a small intermittent stream using slash.

PLAN AHEAD

You may not need to use a structure at a temporary stream crossing if sedimentation can be avoided and the stream bottom and banks will not be disturbed. For example, you can use:

- winter crossings when frozen conditions prevent sedimentation and stream channel disturbance.

Types of temporary stream crossings

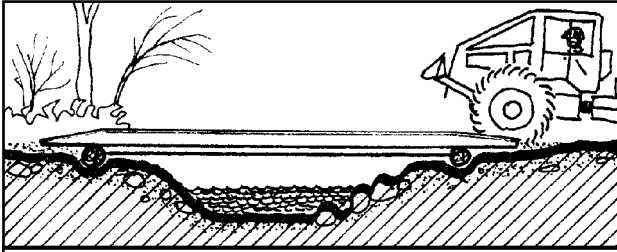

TEMPORARY/PORTABLE BRIDGE
— protect/stabilize stream bank

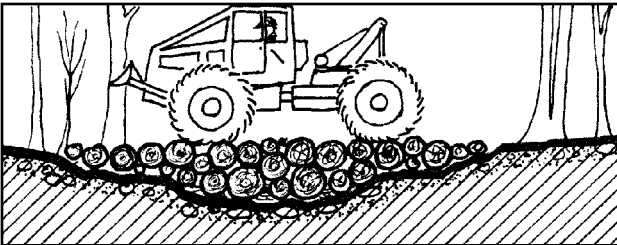

LOG OR POLE FORD
— minimum 8"-10" diameter poles or cull logs side by side
— protect bank and channel
— use well casing to maintain water flow
— remove at closeout

PLAN AHEAD

Permanent stream crossings are used most often on haul roads, and include:

- bridges,
- culverts,
- pipe arches, or
- stone culverts.

Almost all permanent crossings that will impact streams, stream banks or wetlands, require some permit or notification to be filed with NHDES.

Types of permanent crossings



A permanent bridge on a truck road.



An old stone culvert still functioning.

PLAN AHEAD

BMPs

- 2** **Select appropriate crossing locations, based on site and stream conditions.**
- Minimize the number of stream crossings needed and maximize the harvest area accessed by each crossing. By locating all of the crossings during the planning stage, you may be able to reduce the number of crossings needed. Decide whether the amount of wood you gain access to justifies a crossing.
 - Identify the best available sites for stream crossings. Look for:
 - relatively straight, narrow channels, and stable stream sections;
 - level or gently sloping banks and approaches (on both sides) that are stable;
 - approaches that are more or less at right angles to the channel;
 - hard stream bottom (for crossings where the structure rests on the stream bottom, e.g., pole fords); and
 - areas away from important fish spawning habitat.
 - Install crossings when the soil is dry or frozen and the water level is low.
 - Minimize impacts to gravel or cobble streambeds where fish may spawn (especially from late fall to spring when you could harm incubating fish eggs).



See the section on “How to Size and Install Bridges and Culverts” on p. 45 in Section 3, BMPs for Every Stage.

PLAN AHEAD



Permitting requirements depend on the type and size of wetland or surface water resource, and crossing length. Contact the NHDES Wetlands Bureau at (603) 271-2147 or www.des.nh.gov/wetlands.

BMPs

- 3 Select a type of crossing structure that is appropriate for the structure and shape of the stream and the adjacent terrain.** Is there a floodplain or wide, flat wetland next to the stream? These are evidence that the stream floods frequently, and you will need to plan the crossing accordingly. Install additional overflow pipes, dips, or other structures to prevent the crossing from washing out at high flows. Also, keep in mind that the type of crossing structure will affect the efficiency of water flow. Culverts may be preferred in narrow, deep gullies or on V-shaped, steep-sided channels. Bridges or box culverts are preferred for wider streams with low, flat banks.
- 4 Base the opening size on the highest expected stream flows.** Size stream crossings appropriately to reduce the chance that high water levels will undermine or wash out the crossing. Washouts cause erosion and damage the stream. Moreover, repairing or replacing a bridge or culvert is a significant cost, and one that can usually be avoided. (See “How to Size and Install Bridges and Culverts,” in Section 3, BMPs for Every Stage, page 45.)
- 5 Determine the maintenance and closeout needs, and who will be responsible for these tasks.** A well-built stream crossing is an investment that minimizes your risk of causing sedimentation and can assure long-term access. Protect that investment by knowing in advance how it will be maintained and closed out.

KEY ISSUE

Fish Passage

Stream crossings that prevent fish from passing under or through them can reduce the amount of stream habitat available, or the ability of some species to spawn. On the other hand, properly constructed crossings that protect fish passage are often also the easiest to maintain and the least likely to fail or become damaged.



Crossings on streams with fish may be required by law to allow fish passage through or underneath. Call the New Hampshire Fish & Game Department, Inland Fisheries Division for help identifying streams with fish habitat at (603) 271-2501.

Part of the landowner's, forester's, and operator's planning involves determining whether and where there is fish habitat in a stream that will be crossed. A fisheries biologist can help you to determine where maintaining passage is important, the species of fish for which passage is needed, the seasons when passage is most critical, and how much habitat would be kept available by maintaining passage.

In general, temporary crossings have less impact on fish habitat, depending on the type of crossing, the season(s) of use, and the type of stream. Permanent crossings are more likely to create a significant barrier to fish. Bridges or open-bottom culverts that do not restrict the channel or disturb the natural streambed have the greatest potential to protect fish passage. Other crossing structures such as round culverts, pipe arch culverts, and box culverts can be designed so that they do not obstruct fish. Fish habitat is best preserved when these types of culverts are adequately set into the streambed to create a semi-natural stream bottom inside.



Culvert installed below the streambed level to allow fish passage.

Permanent crossings can cause problems for the passage of wetland animals, such as turtles and frogs. Contact the New Hampshire Natural Heritage Bureau at the NH Division of Forests & Lands for the potential of crossings in your project area to affect rare, threatened, or endangered species.

- 1 **Minimize “velocity barriers” by maintaining natural rates of stream flow.** Culverts that constrict flows or are very smooth can increase water speeds beyond the swimming ability of some fish species. Design a culvert’s shape, slope, size, and outlet so that the stream’s natural rate of flow is preserved and fish can swim upstream through the culvert.
- 2 **Minimize “low-flow barriers” by maintaining adequate flows in culverts.** Multiple culverts or other designs that spread out flow or broaden the channel may result in water that is too shallow for fish to pass through, especially during summer.
- 3 **Minimize “exhaustion barriers” to fish.** Culverts that are long, steep, or provide no resting areas may tire fish enough to prevent them from passing through.
- 4 **Minimize “jump barriers”:** Culvert outlets that are set too high (“hanging culverts”) can prevent fish from entering the culvert. In addition, outlets that scour the stream channel can create fish barriers over time as the streambed is washed out and lowered.
- 5 **Minimize “debris barriers”:** Woody material that accumulates at the inlet of undersized culverts can sometimes obstruct passage. Adequately sized crossings may allow debris to pass through, but culverts require regular maintenance to prevent obstructions.
- 6 **Consider possible “behavioral barriers” when choosing the culvert type and material.** The type of culvert bottom may discourage some species of fish from passing over or near them because of specific behavioral traits.

Incorporating these principles into the design of stream crossings can reduce the likelihood of creating barriers to fish. For most stream crossing situations, fish passage can be provided by making sure that:

- structures (bridges and culverts) are at least as wide as the stream channel at normal high water mark;
- culverts are embedded slightly (25% of their diameter) in the stream substrate;
- a natural stream bottom is retained or re-develops within the structure after installation.

BUILD IT RIGHT

Properly installed water crossings preserve water quality, protect your investment in the crossing, and reduce future maintenance costs.

ALL STREAM CROSSINGS

BMPs

- 1 **Minimize disturbance to the stream banks, channel, and streambed during installation, use, and removal.**
- 2 **Minimize and stabilize exposed soils on the approaches within the filter area.** During operations, you can stabilize the approaches with brush or other materials. Once operations are completed...
- 3 **Install diversions on the approaches to prevent channeled runoff from entering the stream from the trail or road, and to disperse it into adequate filter areas.**
- 4 **Build the narrowest roads and trails possible in the filter area and at the crossing.**
- 5 **Do not obstruct water flow or fish passage in the stream. See the guidelines for fish passage on page 40. Install culverts with the bottom resting on or below the stream bed at the inlet and outlet.**
- 6 **Minimize work during wet weather or when the soil is saturated.**

TEMPORARY CROSSINGS

BMPs

- 1 **Stabilize crossing approaches with brush or similar materials, before and during operations.**
- 2 **Protect the approaches by extending temporary bridges well beyond the stream bank.**
- 3 **Install any temporary, portable bridges so that all portions of the bridge are above the stream's normal high water mark. Keep abutments back from the banks, if possible.**



A pole ford.



A temporary bridge.

PERMANENT CROSSINGS

- 1 **If possible, build crossings when streams are dry or at low water. If considerable excavation is necessary during periods of regular or high flow, temporarily divert the water while installing the crossings.**



Permanent crossings within wetlands, surface waters or its banks require permits.

- 2 **Install crossings and approaches using a “no-grub zone” at least the width of the filter area, wherever possible.**
 - Minimize excavation on stream banks and approaches.
 - Construct road approaches using fill (instead of grubbing), leaving the forest floor undisturbed, especially outside the road profile. Consider surfacing with clean gravel or stone. This will stabilize the road surface, prevent it from eroding directly into the stream, and keep mud from being tracked onto the crossing structure.
 - Use geotextile and fill on unstable soils or during wet weather.
 - Set abutments back from the stream’s edge.

- 3 **Design bridges using solid decking or other features to minimize the amount of material that falls through the deck and into the stream.**



Two examples of permanent crossings.

BUILD IT RIGHT

BMPs

- 4 Road ditches should not terminate in a wetland or stream. Use a broad-based drainage dip or similar structure to divert and disperse water off the road just outside the filter area to the undisturbed forest floor.
- 5 Seed and mulch exposed soil on approaches within the filter area (outside the roadbed). This should be done during or immediately after the road installation, in spring, or in early fall—follow the recommendation of the seed supplier. See Section 2, Fundamental BMPs, p. 28 for more information on seeding.

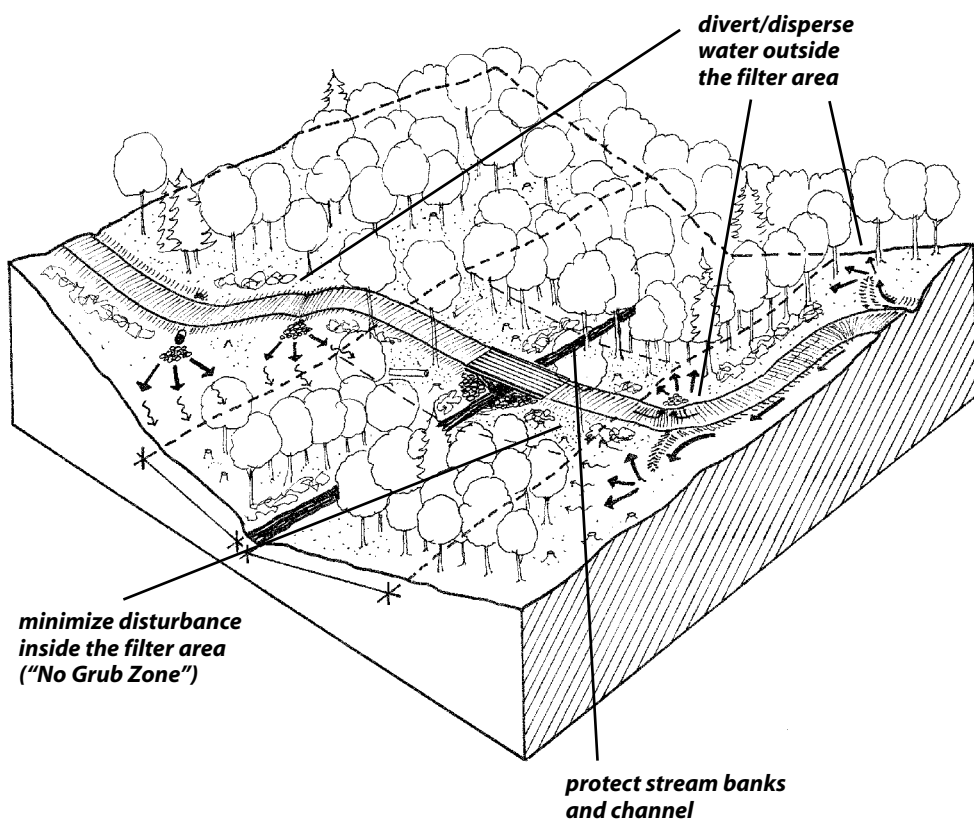

A permanent stream crossing that minimizes water quality impacts.

KEY ISSUE: HOW TO SIZE AND INSTALL *Bridges and Culverts*

Properly sizing and installing bridges and culverts in stream crossings is very important. Doing so will prevent these structures from failing or washing out, requiring expensive repairs or rebuilding. Moreover, washouts can significantly impact a stream's water quality.



Before designing bridges or culverts, know which legal standards apply and what permits may be required.

Planning a stream crossing involves selecting the best crossing location and type of crossing structure. The size of the bridge or culvert will be based on the opening size needed for the size of the stream you are crossing.

STEP 1:

Determine the degree of flooding the crossing must handle without being damaged or washed out. This will depend on what type of crossing you want and how long you anticipate the crossing to be in place. The longer a crossing is in place, the larger the flood that is likely to occur at any particular location.

Design the crossing opening to handle at least normal high water (a 1–3 year flood) for:

- temporary skid trail crossings in place during summer, fall, or winter seasons (but not during spring runoff).

Design for at least a 10-year flood event for:

- temporary skid trail crossings that will remain in place during spring runoff,
- temporary road crossings,

Design for at least a 25-year flood event for:

- permanent road crossings

A 10-YEAR FLOOD EVENT: the highest flood level a stream is likely to reach, on average, in any 10 year period.

EXAMPLE: You need to install a crossing that will be temporary, but you won't be able to remove it until after the spring runoff. You are planning to use a round culvert.

SOLUTION: You need to design the crossing for a 10-year flood event.

STEP 2:

Determine the opening size needed to accommodate the expected flood event. The field method described here calculates opening size based on the actual stream dimensions at the crossing location.

Be sure to use streambank evidence to measure at the normal high water mark—not just the existing water level.

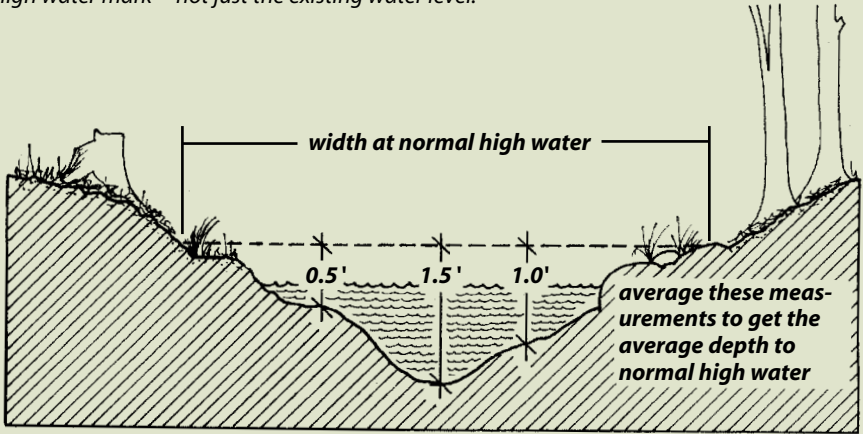

- To accommodate **normal high water** (a 1–3 year flood), multiply (width) x (the average depth at normal high water), or keep all temporary bridge components above the normal high water mark.
- For a **10-year flood event**, use Table B1, or multiply (2.5) x (width of the stream at the crossing location at normal high water) x (average depth of the stream at normal high water).

**Table B1
10-year Flood
Crossing Opening Size
(sq. ft.)**

Stream Width*	Average stream depth*			
	(ft)			
ft.	0.5	1	1.5	2
1		2.5	3.75	5.0
2	2.5	5.0	7.5	10
3	3.75	7.5	11.3	15
4	5.0	10	15	20
5	6.25	12.5	18.8	25
6	7.5	15	22.5	30

* at normal high water mark

Bold: bridge, arch, or embedded multiple pipe may be preferred on these larger streams

- For a **25-year flood event**, use Table B2, or multiply (3.5) x (width of the stream at the crossing location at normal high water) x (average depth of the stream at normal high water).

EXAMPLE: The average depth of the stream at your chosen crossing site is (1 ft.+1.5 ft.+0.5 ft.) / 3 = 1 ft. You determine the width is 5 feet.

SOLUTION: You use Table B1 because you are designing for a 10-year flood. That table shows that the opening size at the stream crossing should be 12.5 sq. ft.

STEP 3:

Design the bridge or culvert to meet or exceed the minimum opening size.

- **For bridges or box culverts**, determine a width and height that, multiplied together, produce a result that is at least as great as the square footage you determined you needed in Step 2. Bridges should be installed above the normal high water mark or higher.
- **For round culverts**, select a culvert size using Table C.
 - Find the opening size in the first column that is equal to, or the next size up from, the opening size you determined in Step 2.
 - Find the culvert diameter for that opening size in the second column.
 - If you plan to use more than one culvert, be sure the total opening size of all culverts adds up to the minimum opening size you determined in Step 2. *Add opening sizes of the culverts, not culvert diameters.*

**Table B2
25-year Flood
Crossing Opening Size
(sq. ft.)**

Stream Width*	Average stream depth* (ft)			
	0.5	1	1.5	2
1	1.75	3.5	5.25	7.0
2	3.5	7.0	10.5	14
3	5.25	10.5	15.8	21
4	7.0	14	21	28
5	8.75	17.5	26.3	35
6	10.5	21	31.5	42

* at normal high water mark
Bold: bridge, arch, or multiple pipe may be preferred on these larger streams

**Table C
Culvert Diameter
and Opening Sizes**

Opening size (sq. ft.)	Diameter (inches)
1.75	18
2.40	21
3.15	24
4.90	30
7.05	36
9.60	42
12.55	48
15.90	54
19.65	60
23.75	66
28.26	72

- **For pipe arches**

- calculate the required opening size as in Step 2.
- double the opening size, and
- use Table C to find the pipe arch diameter for that opening size. (The opening of pipe arches is approximately half that of round culverts of the same diameter). Make sure the diameter is wide enough to install bottomless/half circle arch footings above the normal high water mark.

EXAMPLE: You plan to install a round culvert, so you look for your required opening size of 12.5 sq. ft. in the left-hand column of Table C.

SOLUTION: 12.5 isn't listed, but the next highest number is 12.55. The diameter size listed opposite 12.55 in the right-hand column is 48 inches. This is the size culvert you need.

Had you decided to use two culverts instead of one, you would still use the total required opening size of 12.5 sq. ft. Two culverts of 6.25 sq. ft. each would meet the requirement ($6.25 + 6.25 = 12.50$). Looking at Table C again, the opening size one size larger than 6.25 is 7.05, and the diameter of this size culvert is 36 inches. So you can install one 48"-diameter culvert, or two 36" culverts.

STEP 4:

Adjust the bridge or culvert size or type as necessary to:

- minimize disturbance to the stream channel and banks,
- allow for unrestricted normal flows,
- allow fish to pass when water is present, and
- ensure that the water velocities do not increase because of the nature of the culvert material. Water velocities often are the most important factor regarding fish passage.



Tip: In most situations, the width of the opening for a bridge or culvert should be at least as wide as the stream channel width at the normal high water mark.

EXAMPLE: This stream has fish in it, and is relatively narrow.

SOLUTION: One 48" culvert will fit the stream better than two smaller ones. You decide to use the 48" culvert. This will ensure that, even at its lowest level, water will run through the culvert and fish can pass through.

When installing permanent culverts:

- Set the culverts with the bottoms slightly below the bed of the stream, and at a 2-3% slope. Avoid “hanging” culverts where the bottom of the culvert outlet is above the low water level.
- Extend the culvert inlet and outlet 1 foot or more beyond the fill or roadbed.
- Cover with compacted backfill to a depth equal to half the culvert diameter, or at least 1 foot deep.
- Stabilize the inlet and outlet of culverts and bridges using cobbles, timber abutments, or other armoring.

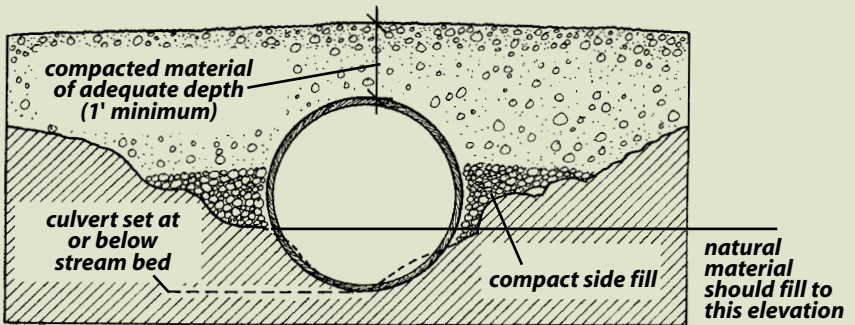
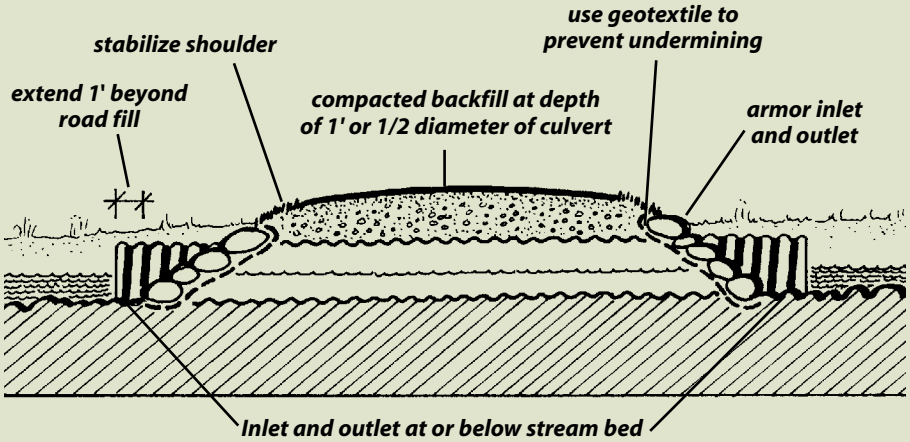

AS AN ALTERNATIVE to this field method, consider using a hydrological analysis model and/or assistance from a professional engineer or someone who knows fluvial geomorphology, especially for permanent crossings. See the “References” section for more information.

MAINTAIN IT

ON ALL CROSSINGS

BMPs

- 1 **Do not allow ditches to terminate directly into the stream, wetland, or the filter area.** Runoff should be dispersed onto the undisturbed forest floor before it reaches the filter area.
- 2 **Make sure the approaches within the filter area are stabilized** (see “Stabilizing Exposed Soil” on page 24 in Section 2, Fundamental BMPs).
- 3 **When grading or rock-raking approaches, do not drag material onto the crossing.**

TEMPORARY CROSSINGS

BMPs

- 1 **Stabilize the soil on stream crossing approaches in the filter area by using slash, brush, or log corduroy.**
- 2 **If there is rutting or channeling on the crossing approaches, disperse the water flow to an undisturbed, stable filter area using water bars or similar structures.**

PERMANENT CROSSINGS

BMPs

- 1 **Establish a regular monitoring and maintenance schedule for permanent stream crossings.**
- 2 **Make sure the crossing approaches are not carrying sediment to the stream.** Maintain and re-stabilize them as needed.
- 3 **See if the abutments, armoring, and bank stabilization measures are being undermined or damaged, and replace or repair them as necessary.** Severe undermining may indicate a poor location for the crossing, improper sizing, or incorrect installation, and can only be corrected by relocating or redesigning the crossing.
- 4 **Periodically remove debris and other materials that may block or constrict the culvert or bridge opening.** Using 18" minimum diameter culverts greatly reduces the need for this maintenance work.

CLOSE IT OUT CORRECTLY

Closeout BMPs will help minimize future damage at both permanent and temporary crossing sites.

BMPs

- 1 As a first step, identify the long-term monitoring and maintenance needs appropriate to the harvest site and communicate these to the landowner, forester, and logger.** Determine who will be responsible for these tasks.
- 2 Remove temporary structures, slash, and/or other materials from the stream when the crossing is no longer used.** Do not remove debris that has fallen into the stream naturally.
- 3 Leave brush in place on the approaches and banks (above the normal high water mark) to ensure ongoing stabilization when you closeout.**
- 4 Remove bed logs used for temporary bridges unless doing so may cause more disturbance.**
- 5 After the harvest, stabilize the remaining exposed soil on the approaches in the filter area.** Use additional brush, hay, or other materials. If large areas are disturbed, spread grass seed and mulch.



Closeout of a temporary stream crossing.



HIGHEST PRIORITIES

- **Avoid crossing wetlands and streams whenever possible.**
- **Minimize soil disturbance, soil movement, and sedimentation.**
- **Maintain water movement, especially in the top 12 inches of soil.**

WETLAND CROSSINGS

Wetlands are areas where soils are saturated or flooded for part of the year, where water-loving plants are found, and where soils have taken on special characteristics. (See page 8, Section 1, Water Movement for more discussion and examples of wetlands.) The large amount of water and organic matter in wetland soils make them difficult to work in. Wetland soils have low weight-bearing capacity and therefore are weaker than upland soils. In addition, it is common for water to be moving through the soil near the surface.

Using BMPs in wetlands helps minimize two primary impacts: sedimentation and the alteration of water flow through the wetland soils. Sedimentation is primarily a concern for non-forested wetlands. Several wetland BMPs provide ways to increase the strength, or bearing capacity, of the soil (minimizing rutting) and to maintain water movement through the wetland soil.

PLAN AHEAD

BMPs

- 1 **Construct permanent wetland crossings only if there is no reasonable alternative.** Can the wetland crossing be avoided by re-routing the road or trail?
- 2 **Get assistance from a professional engineer or licensed forester if you need to construct permanent roads in wetlands.** These professionals can minimize your costs as well as the impacts on water quality.
- 3 **Avoid building winter crossings in areas with moving water that does not freeze well.**
- 4 **Design permanent wetland crossings that will remain stable and will not restrict water flow during wet periods, especially at spring high water.**
- 5 **Determine the maintenance and closeout needs, and who will be responsible for these tasks.**

BUILD IT RIGHT

BMPs

1 **Minimize the length and width of the road or trail within the wetland.**

2 **Temporary crossings are preferred.** Use wooden mats, log corduroy, or similar structures to cross wetlands.

3 **Stabilize the approaches to wetland crossings, and the road and trail surfaces within the wetland itself.** The approaches should be stabilized out to the edge of the filter area. Filter areas around wetlands begin at the border between non-forested and forested areas (to the degree that it can be identified.) See page 24 in Section 2, Fundamental BMPs, for more information on soil stabilization.

4 **Filter areas within forested wetlands need to be stabilized, too.** In these cases, the filter area is based on the location of streams that flow through the wetlands.

TEMPORARY CROSSINGS

Soil disturbance, fill, and other alterations in wetlands requires a permit from NHDES at (603) 271-2147 or www.des.nh.gov.wetlands.



Wetland culverts allow for cross drainage if the road fill does not.

BUILD IT RIGHT

BMPs

- 1 Cross wetlands on frozen ground if possible.
- 2 Use brush, if necessary, to increase the soil's load-bearing capacity.
- 3 Stop harvesting operations if rutting is unavoidable.



Log corduroy used for a skid trail across a wet area.

BUILD IT RIGHT

PERMANENT CROSSINGS

BMPs

- 1 Use road base materials such as waste wood, poles, corduroy, or large stone that permit water to flow through the road's sub-base.

If necessary, use these materials in combination with geotextiles to keep the different layers of road material separate or to isolate the wet soils. This will increase the bearing capacity of the road so it can stand up to heavier loads and traffic.



The length of the wetland crossing may affect the type of wetlands permit necessary.

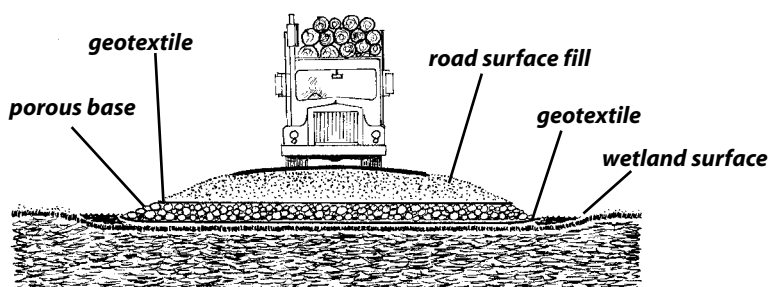

Use geotextile to keep fill from mixing with the wetland soil.

BMPs

- 2 Limit excavation and other disturbances to the organic mat and the soil. If you can maintain the natural water flow without ditching, do so.

BUILD IT RIGHT

BMPs

- 3 If the drainage through the road base is not adequate (if the road is damming water), install cross-draining culverts or other structures to allow water to flow through.

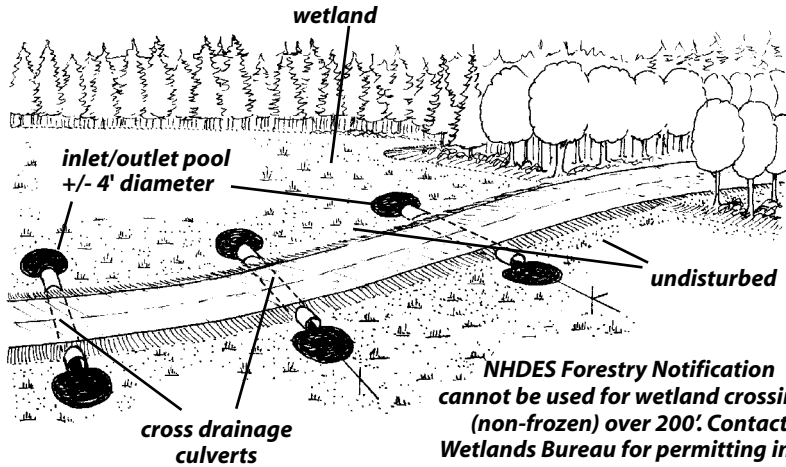

BMPs

- 4 Use side ditches, parallel to the road, only when they are needed to collect flowing surface and subsurface water. Disperse the water to undisturbed areas.

MAINTAIN IT

BMPs

- 1 Use temporary crossings when the ground is frozen. Pack or plow the snow to help freeze the ground.
- 2 Keep cross drainage structures functioning by clearing debris that can plug them.
- 3 Whenever possible, use equipment with wide tires, tracks, or other features that distribute the weight.

CLOSE IT OUT CORRECTLY

BMPs

- 1 Identify the long-term monitoring and maintenance needs appropriate to the harvest site and communicate these to the landowner, forester, and logger.
- 2 After harvesting, remove wooden mats, log corduroy, or similar temporary structures used to cross wetlands.



HIGHEST PRIORITIES

- **Construct new roads outside of filter areas, except at stream and wetland crossings.**
- **Where you must cross surface waters or wetlands, minimize the length and width of road.**
- **Keep water off the road with drainage systems that are well designed and maintained.**
- **Divert and disperse runoff onto undisturbed forest floor outside filter areas.**

TRUCK ROADS

This section contains BMPs for roads used primarily for hauling wood from the landing by truck. The design, materials, specifications, and use of these roads vary widely, but they are all referred to as “truck roads” in this section, whether it is a short 100-foot spur, or an extensive road system.



BMPs for truck roads are *critical* for protecting water quality in and around filter areas, and for minimizing runoff.

The construction and use of truck roads can sometimes cause significant water quality problems. Road construction may alter the flow of water over and through the ground. Truck roads expose soil over a large area and get heavy use. They often require permanent stream crossings. All of these factors pose risks to the quality of nearby waterbodies. However, most negative impacts on water quality can be avoided if truck roads are designed, constructed, and maintained properly.

Well-planned and -built roads make sense both economically, and environmentally. Road BMPs:

- extend the seasons the road can be used,
- reduce road wear and maintenance costs,
- enable trucks to haul heavier loads,
- lower truck maintenance costs,
- reduce travel time, and
- protect water quality during and after harvests.



PLAN AHEAD

ALL TRUCK ROADS

BMPs

- 1 **Determine the size and type of road needed.** Plan roads that are appropriate to the immediate harvest needs and the long-term forest management objectives. Consider the harvest characteristics (the volume and types of products, terrain, soils), all current uses of the road, and other features of the property (the shape of the lot, proximity to neighboring lots, and long-term management plans).
- 2 **Identify the future forest management uses of the road, after the current operation is closed out.** Is the road likely to be used for precommercial operations like pruning? Is access for fire suppression important? How often will the road be used for harvesting?
- 3 **Determine the maintenance and closeout needs, and who will be responsible for these tasks.**
- 4 **Know the legal requirements for roads.** Are local or state permits required?

NEW ROADS

BMPs

- 1 **Plan and design new roads that will meet your harvest needs.**
 - What size truck will be used?
 - During what season will you be cutting, and how long will the harvest last?
 - What are the safety considerations?
 - What are the long-term road uses:
 - permanent or temporary access?
 - recreation or other road uses?
 - future harvests?
- 2 **Think about how you want the road to fit into the access system for the entire property. Elements to consider are:**
 - the direction of travel,
 - turnarounds,
 - entrances,
 - total road length,
 - connections to other roads, and
 - number and type of wetland and stream crossings.

PLAN AHEAD

OLD ROADS

BMPs

- 1 **Determine if old roads can be re-used or upgraded with minimal impacts to water quality.** Consider the road's location, the existing drainage (i.e., where does the water flow?), the potential for additional drainage, and intended uses.
- 2 **Consider relocating roads that:**
 - encroach on a filter area unnecessarily;
 - have poorly placed or unnecessary stream crossings;
 - have poor drainage; and/or
 - have unstable soils that cannot be improved (especially gullied roads, roads in ravines, or roads that collect and hold water).



In some situations, there may be laws that govern when, where, and how old roads can be upgraded. Contact the New Hampshire Department of Transportation, and/or the town Selectman for more information.

PLAN AHEAD

LOCATING AND LAYING OUT NEW ROADS

Lay out new roads so that they fit the terrain, ground conditions, and equipment you will be using. It is often helpful to use a topographic map and aerial photos for this.



These recommendations are not intended to substitute for obtaining engineering advice or abiding by regulations in the appropriate circumstances.

BMPs

1 Identify important features on maps, aerial photos, and in the field.

Be sure to include:

- the boundaries of the property and the areas to be harvested;
- seasonal or permanent water bodies and filter areas;
- ephemeral, wet, or poorly drained areas (wetlands) next to water bodies;
- existing roads, entrances, landings;
- stands; and
- terrain features such as steep slopes, flat benches, rock outcrops, gullies, bowls, and ridges.

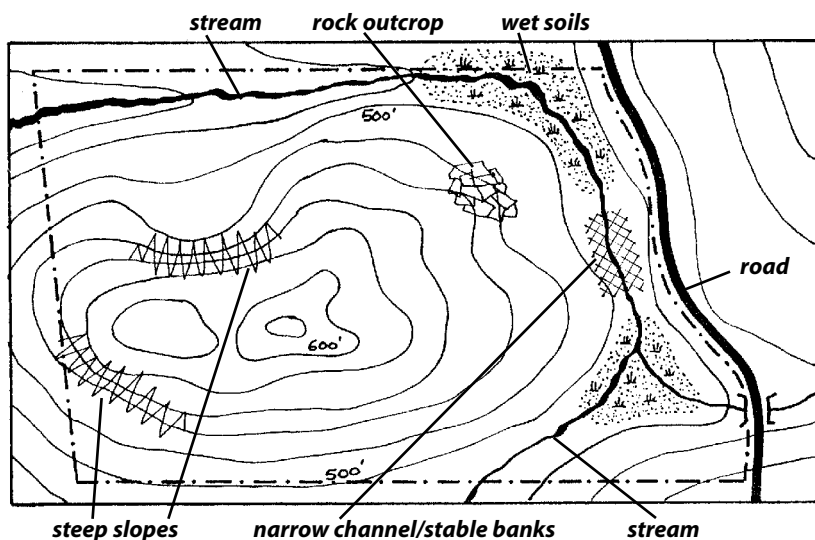

Map out important features on the ground first...

BMPs

- 2 Mark the harvest boundaries, water bodies, new road locations, stream crossings, and filter areas on-site.
- 3 Lay out roads where there are better-drained soils, gentle slopes (ideally 2–5%), and good stream crossing locations.
- 4 Minimize the overall road length, while still meeting operational objectives, including preferred log landing locations.
- 5 Minimize road sections where water may be difficult to drain or divert.

Pay special attention to:

- road grades greater than 10% (over 15% in mountainous terrain);
- long, unbroken grades;
- long, flat stretches; and
- roads laid out straight up- or downhill that still require ditches.

- 6 Avoid filter areas (except at appropriate stream crossing locations); ephemeral, wet, or poorly drained areas (wetlands); floodplains; and steep slopes, outcrops, gullies, or ravines.

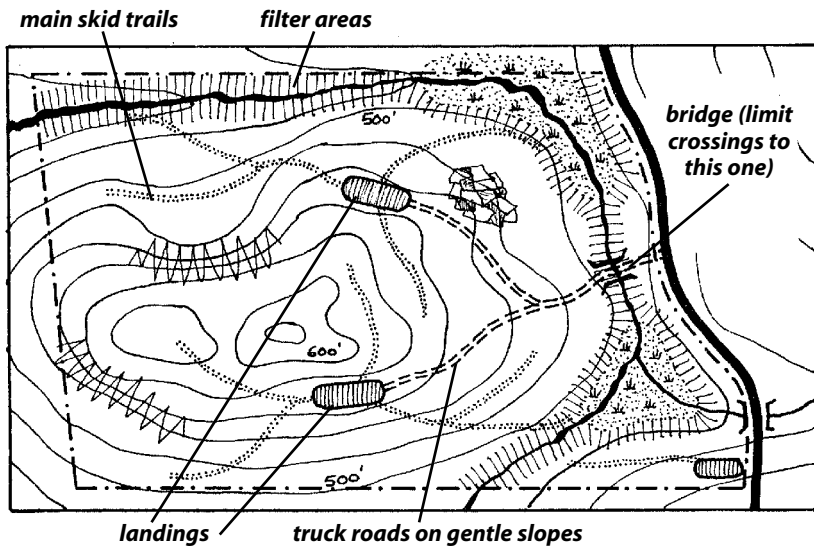

...then lay out the roads, trails, etc.

BUILD IT RIGHT

BMPs protect water quality when building new roads or upgrading old ones. Using BMPs protects the condition of, and investment in, the road.

TIMING

BMPs

- 1 **Whenever possible, construct roads during dry periods or when the ground is frozen.**
- 2 **Minimize work during heavy rains and/or wet periods.**
- 3 **Plan how and when roads built during the winter will be stabilized.**
- 4 **If possible, build roads before you intend to use them heavily so that they have time to settle and stabilize.**



CONSTRUCTION

BMPs

- 1 **Shape roads to move water off the road surface using a crown, an out-slope (this may present a safety hazard in icy conditions or on curves), or an in-slope (this will often require ditches and cross-drainage structures).**
- 2 **Use gravel, crushed stone, or other surface material (with or without geotextile) to stabilize roads, shed water, and increase the weight-bearing capacity.**
- 3 **Maintain cut and fill slopes at a natural angle of repose or less (2:1 for average soils) wherever possible.**

OUT-SLOPED ROAD

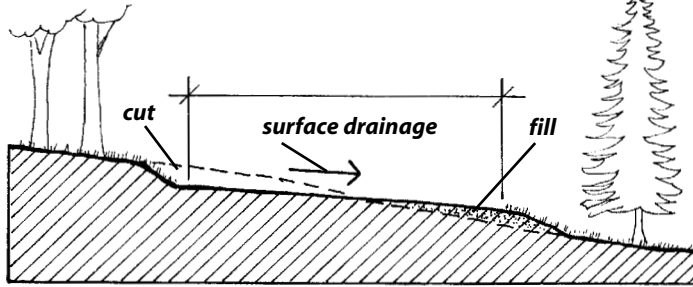

IN-SLOPED ROAD

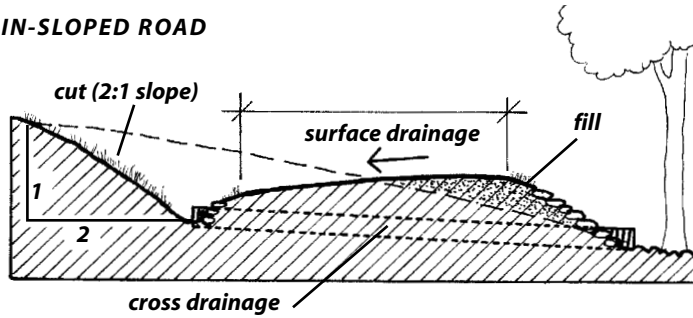

CROWNED ROAD

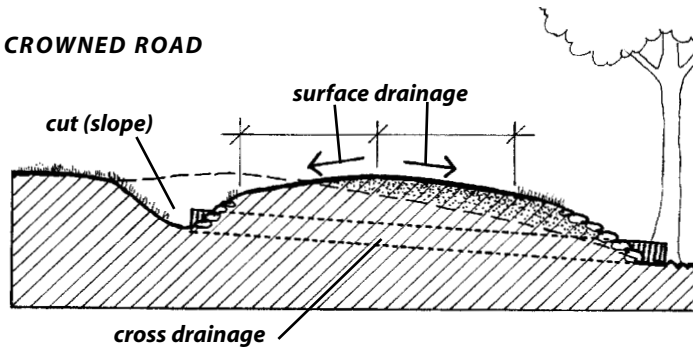

BMPs

- 4 As the construction progresses, stabilize areas of exposed soil that will receive road runoff such as cut-and-fill slopes, steep road shoulders, and erosion-prone soils in filter areas.
- 5 Use temporary sediment barriers to slow flowing water and trap sediment during construction, such as staked haybales, stone, check dams, or a combination.



KEY ISSUE

Controlling the Water

DRAINAGE AND DIVERSION STRUCTURES

Water diversions minimize the amount of run-off that reaches water-bodies. These diversions can include cross-drainage structures, ditches, turnouts, and other structures that divert water away from the road and disperse it into areas of undisturbed forest floor.

BMPs

- 1 **Construct roadside ditches to carry runoff from the road surface and uphill areas. Ditches with a flattened U-shape (a broad, rounded bottom and sloping sides) are preferred—avoid straight-sided ditches.**

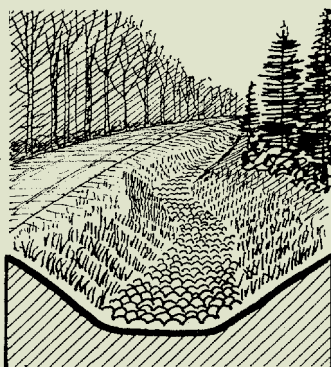

Grass and stone stabilized ditch

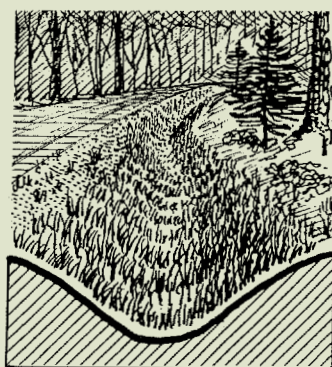

U-shaped, grass stabilized ditch

BMPs

- 2 **Divert water off the road surface and away from the road using natural dips (or grade breaks), broad-based dips, culverts, turnouts, or similar techniques.**

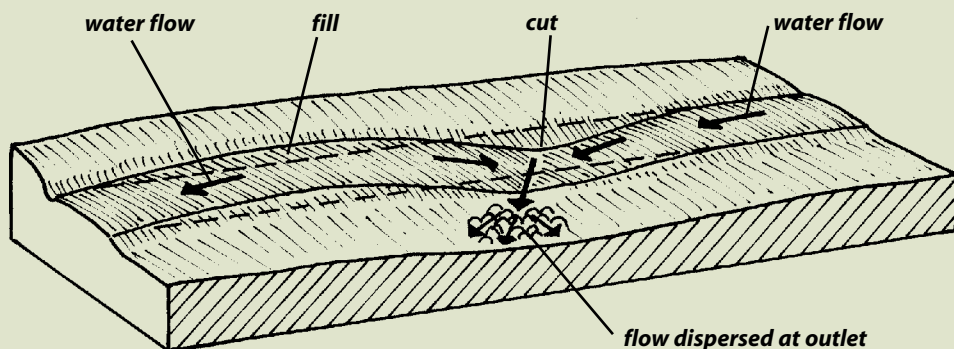

- 3 **Space water diversions close enough together to control the volume and speed of water.** The recommended spacing varies widely, depending on the grade (steeper grades require closer spacing). Refer to Table D for the spacing most appropriate for the slope at hand. Choosing appropriate locations for the diversions may be more important than spacing on some sites.
- 4 **The location and spacing of culverts is often more important than their diameter.** For round culverts, use at least a 15- to 18-inch diameter size to minimize plugging and maintenance.
- 5 **Disperse water flowing from the outlets of diversion structures or from downhill road shoulders using brush berms, riprap aprons, or other methods—before it enters the filter area.**
- 6 **Construct settling basins outside the filter area if water from ditches cannot be diverted off the road onto undisturbed forest floor.** Settling basins will require periodic maintenance and cleaning.

Table D
Spacing for
Water Diversion

Road Grade (%)	Spacing (ft)
0-2	250-500
3-5	165-250
6-10	140-165
11-15	125-140
16-20	100-125
21+	<100

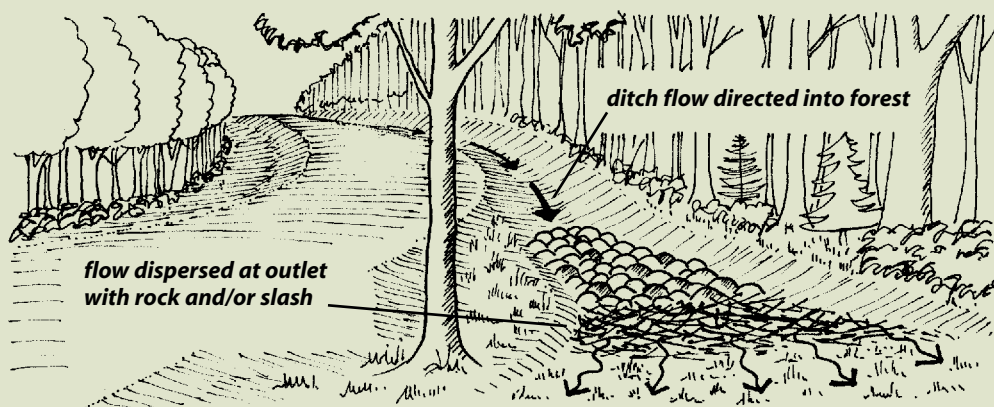

CROSS-DRAINAGE CULVERTS

Cross-drainage culverts may be metal, plastic, concrete, or wood (box culverts). Permanent or temporary culverts are most effective when installed according to the following specifications.

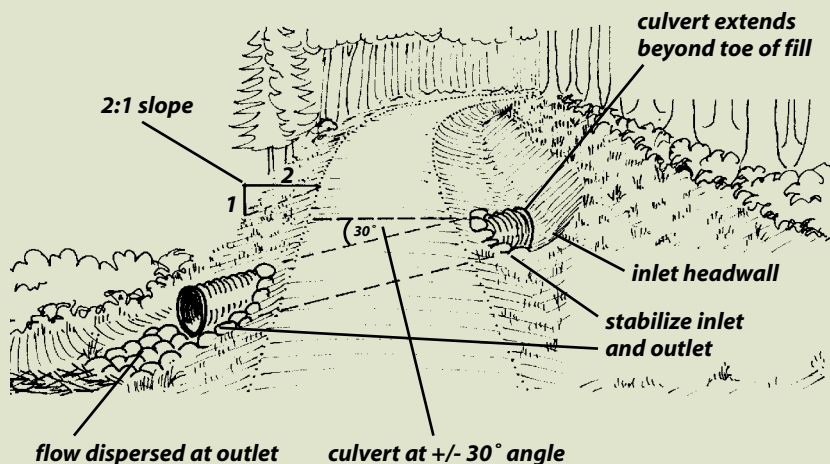

BMPs

- 1 **Install a berm or diversion headwall that directs ditch water into the culvert and protects the culvert end.**
Ideally, the berm is left in place during the excavation of the ditch.



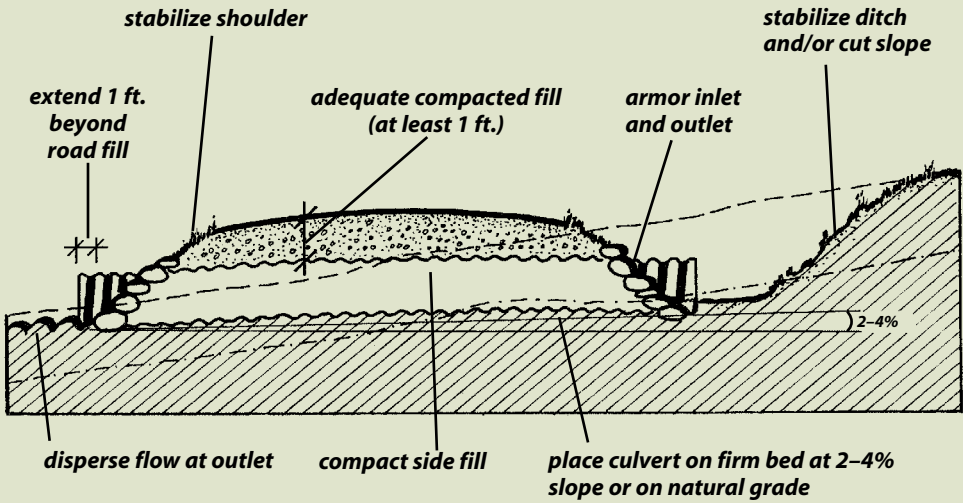

BMPs

- 2 Install culverts at a 2–4% slope and at a 30° angle to the road.
- 3 Stabilize areas around the inlet and outlet with riprap or other material, and extend the culvert at least 1 foot from the road fill on either end.
- 4 Install culverts on top of adequate bedding material (native soil or, if necessary, added fill) that is free of branches or large rocks.
- 5 Cover the culvert with compacted material to a depth of half the culvert diameter (or a minimum of 1 foot) or to the manufacturer’s recommended specifications.



MAINTAIN IT

Proper road maintenance protects water quality and the road by keeping the BMPs functioning. If these structures fail, significant water pollution can result, most often during severe rainfall or snowmelt. Many of the structures used to divert water from road and trail surfaces should be maintained both during and after the harvest (unless the road is closed out). Periodically removing accumulated sediment in these structures will keep them operating as they were designed to.



BMPs

- 1 **Avoid using roads during wet seasons or after heavy rains.**
Let wet roads dry out or freeze before re-using them.
- 2 **Regrade the road surface if the crown is lost from heavy use.**
This prevents water from running in the wheel ruts. Don't leave material at the road's edge. Such "false ditches" can carry water along the road edge, bypass the BMPs, and channel the water into filter areas or crossings.
- 3 **Inspect ditches to make sure they have not begun to fill in, slump, or develop channels. Clear blocked ditches.**
- 4 **Re-shape and/or stabilize ditches as needed with erosion control mats, or by other methods.**
- 5 **Stabilize exposed soils within filter areas and areas that drain directly to waterbodies. Where your original stabilization techniques are no longer effective, restabilize using additional materials (mulch, brush, and/or seeding) or other techniques.**
- 6 **Keep cross-drainage culverts free of debris and accumulated sediment at their inlet and outlet. Repair the outfall protection if water is eroding the soil around it.**
- 7 **Maintain the riprap or other armoring at culvert ends to prevent erosion around the pipe and to protect the ends from physical damage.**
- 8 **Replace culverts that have been undermined or crushed, before they fail.**
- 9 **Clean out settling basins, ponds, and check dams well before they fill up with sediment.**

CLOSE IT OUT CORRECTLY

Most erosion and sedimentation from roads happens within two years of the operation. Road closeout BMPs are best used before leaving the site for any extended period, or after the harvest is completed—even if you expect to use the road again. These BMPs prevent damage, ensuring that the road can be used again in the future. Of course, they also prevent water pollution.

BMPs

- 1 **As a first step, identify the long-term monitoring and maintenance needs appropriate to the harvest site, communicate these to the landowner, forester, and logger, and decide who will be responsible for each task.**
- 2 **Close out road sections as portions of the harvest are completed.**
- 3 **Make sure drainage structures are functioning correctly, are free of debris and accumulated sediment at their inlet and outlet, and are adequately sized for storm events.**
- 4 **Stabilize and seed exposed soils outside the travel surface, within filter areas, and in areas that drain to waterbodies.**
- 5 **Reshape and stabilize the road surface and ditches as needed.**
- 6 **Remove temporary sediment barriers such as hay bales and filter fences.**
- 7 **Divert water entering the road from skid trails, log landings, or other roads.**
- 8 **If necessary, limit or block vehicle access to prevent damage or rutting (if this is compatible with the landowner's objectives).**



Revegetated road ditches carry water without eroding.



HIGHEST PRIORITIES

- **Locate landings on sites with well-drained soils and gentle slopes whenever possible.**
- **Locate landings out of filter areas and at least 100 feet from waterbodies (including wetlands).**
- **Minimize the amount of water entering the landing from roads or skid trails.**
- **Stabilize and maintain the landing surface.**

LOG LANDINGS

Log landings are the cleared areas in the harvest area where logs and other products are brought from the woods and piled, sorted, or stored before being loaded onto trucks. Log landings are sometimes referred to as log yards or decks. Landings are also where hazardous materials often are stored or used to maintain and repair equipment and roads. Please refer to the “Hazardous Materials” section on page 88 for BMPs that deal with these substances.

BMPs will help prevent negative impacts to water quality and can extend the use of log landings during—and long after—the harvest. Landings are often the most visible part of the operation. BMPs may help maintain or improve the landing’s appearance while demonstrating conscientious work to the public.

PLAN AHEAD

Log landings are busy places where a relatively large amount of soil may be exposed or disturbed. It is therefore important to locate landings away from water and maintain erosion controls.



PLAN AHEAD

BMPs

- 1 Use topographic, soils maps and field information to decide the best location for log landings. Preferred sites are:
 - on well-drained soils;
 - on gently sloping (not flat) ground; and
 - outside filter areas.
- 2 Keep the landing as small as possible and still meet the requirements of the equipment, the quantity and type of products, and safety.
- 3 Mark the landing boundaries before construction begins.
- 4 Lay out skid trails and roads so that water cannot flow into or out of the landing where they enter.
- 5 Plan how you will stabilize exposed soil on the landing after the job.
- 6 If landings already exist, determine if they can be reused with adequate erosion controls. If not, relocate them.

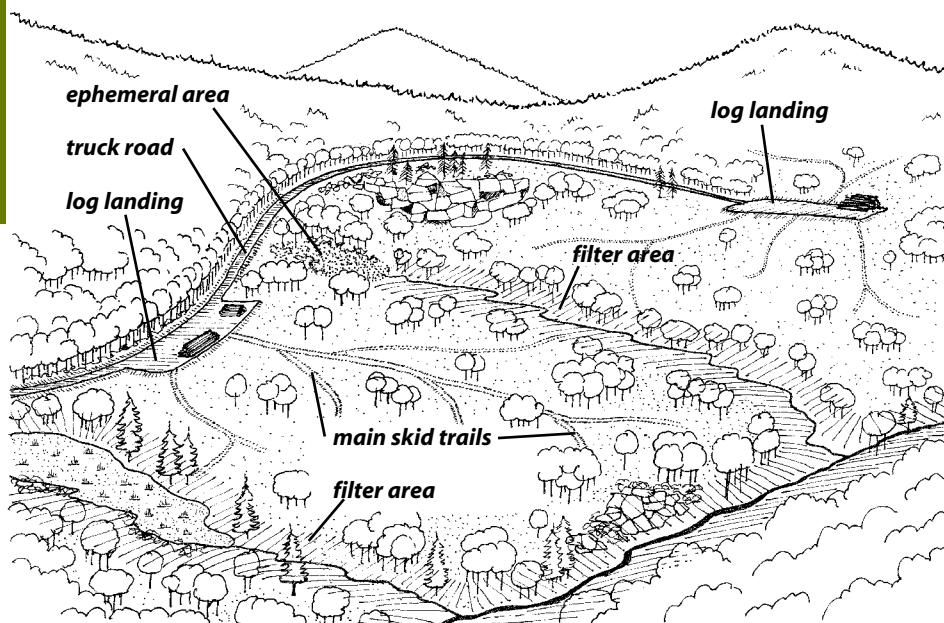

Select landing locations carefully.

BUILD IT RIGHT

BMPs

- 1 Minimize the area of the landing that is stumped or grubbed.** Logs may sometimes be piled on relatively undisturbed soil or forest floor, within reach of loading equipment.
- 2 Install drainage ditches, water bars, or berms to drain the landing to areas of undisturbed forest floor, or to road drainage systems that can handle the amount of water coming off the landing.**
- 3 Surface the landing with wood chips, stone, or aggregate if it will help stabilize the surface and shed water.** Use these materials on top of geotextiles, if necessary.
- 4 During construction, install temporary sediment barriers (such as hay bales or silt fences) to keep newly exposed soil from entering flowing water and filter areas.** See page 29 in Section 2, Fundamental BMPs, for more information on temporary sediment barriers.



Slash and logging debris can help stabilize exposed soil on log landings.

MAINTAIN IT

BMPs

- 1 Maintain the landing surface to keep water from collecting or channeling.
- 2 Maintain drainage structures on roads and trails to keep water from entering the landing.
- 3 Install temporary or short-term measures (e.g., waterbars) on skid trails if significant rain is likely during operations.
- 4 Allow landings to dry out after significant rainfall.



A well-maintained, well-drained landing.

CLOSE IT OUT CORRECTLY

BMPs

- 1 As a first step, identify the long-term monitoring and maintenance needs, decide who is responsible for these tasks, and make sure everyone involved in the operation is notified.**
- 2 Prevent water from entering or exiting the landing via roads or skid trails.** If necessary, install water bars or similar diversions to divert flowing water to the undisturbed forest floor.
- 3 Seed, mulch, or otherwise stabilize the landing to establish a vegetative cover.** This is particularly important near waterbodies and filter areas. If the soils in the landing are severely compacted, some site preparation may be necessary before vegetation can take root.
- 4 Limit vehicle access to the landing** (if this is compatible with the landowner's objectives).
- 5 Remove any temporary erosion control structures such as staked hay bales or silt fences.** Make sure that permanent measures are in place.



Seeded and mulched landing area.



HIGHEST PRIORITIES

- Minimize water channeling in trails and entering filter areas.
- Limit the amount of exposed soil.
- Leave enough vegetation to provide important natural functions within filter areas.
- Close out trails appropriately.

TRAILS AND HARVESTING

Much of the activity on a harvest operation happens on logging trails, away from truck roads and log landings. Trails may be cut for skidders, forwarders, felling machinery, and other equipment. Logging trails often require little or no excavation, and are usually temporary.

PLAN AHEAD

WORKING IN FILTER AREAS

Clearing trails and cutting trees, by themselves, may have a limited or temporary impact on water quality. However, when trails and trees are cut within a filter area, the potential for negative impacts on water quality increases.

BMPs

- 1 Determine how much and where to cut within the filter area first; then plan your trail layout.** Limiting the harvest activity within the filter area is an important practice for protecting water quality during harvesting.
- 2 Delineate filter areas in the field that are of appropriate width around waterbodies and wetlands.** The size of the filter area should be based on site and stand conditions, but at least the width shown in Table A in Section 2, Fundamental BMPs, on page 22.



PLAN AHEAD

TRAIL LAYOUT

Locating and laying out skidding or forwarding trails in advance, especially main trails, can prevent problems. Consider the terrain, where the wood is, the lean of the timber, available equipment, the grade, soil conditions, skidding distance, filter areas along streams, and stream crossings. Good planning may reduce the skidding costs, and can reduce or eliminate the need for additional BMPs and structures.

BMPs

- 1 **If possible, lay out trails for winter harvests in advance when there is no snow on the ground. Ideally, lay out trails on bare ground during wet seasons.**
- 2 **Whenever possible, lay out main trails to avoid waterbodies and their associated filter areas, wet spots, seeps, wetlands, and the bases of slopes.**
- 3 **Keep trails out of stream channels and off the banks of waterbodies.**
- 4 **Construct trails on the contour, if it is safe to do so.**
Avoid skidding straight up and down hills. Remember that trail systems that run downhill to the landing tend to concentrate runoff.

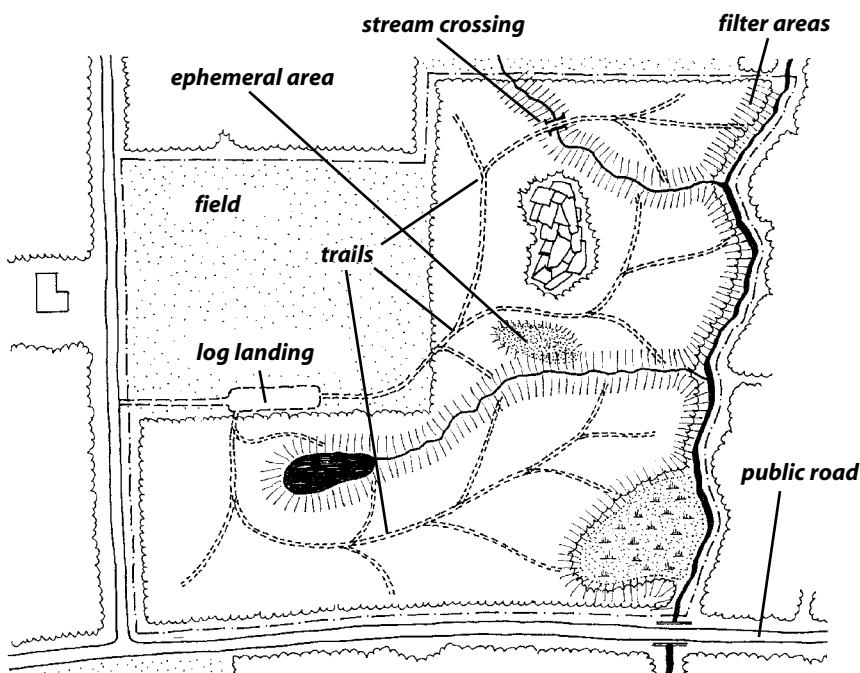

Example of small lot layout.

PLAN AHEAD

BMPs

- 5 Plan to divert water from the trails to the undisturbed forest floor.
- 6 Minimize trail sections on steep slopes (>15%) wherever possible.
- 7 Plan to harvest during appropriate soil and weather conditions (preferably on dry or frozen ground).
- 8 Before you use old trails in the harvest area, consider whether water will run in them and where this water goes. Use existing trails only if runoff can be kept out of waterbodies and wetlands by:
 - diverting water from the trail (for example, by using waterbars); and
 - using brush or other materials to prevent ruts from developing or deepening.
 - If old trails are deeply rutted and the site cannot be harvested without additional rutting, consider harvesting on frozen ground and/or relocating the skid trails.

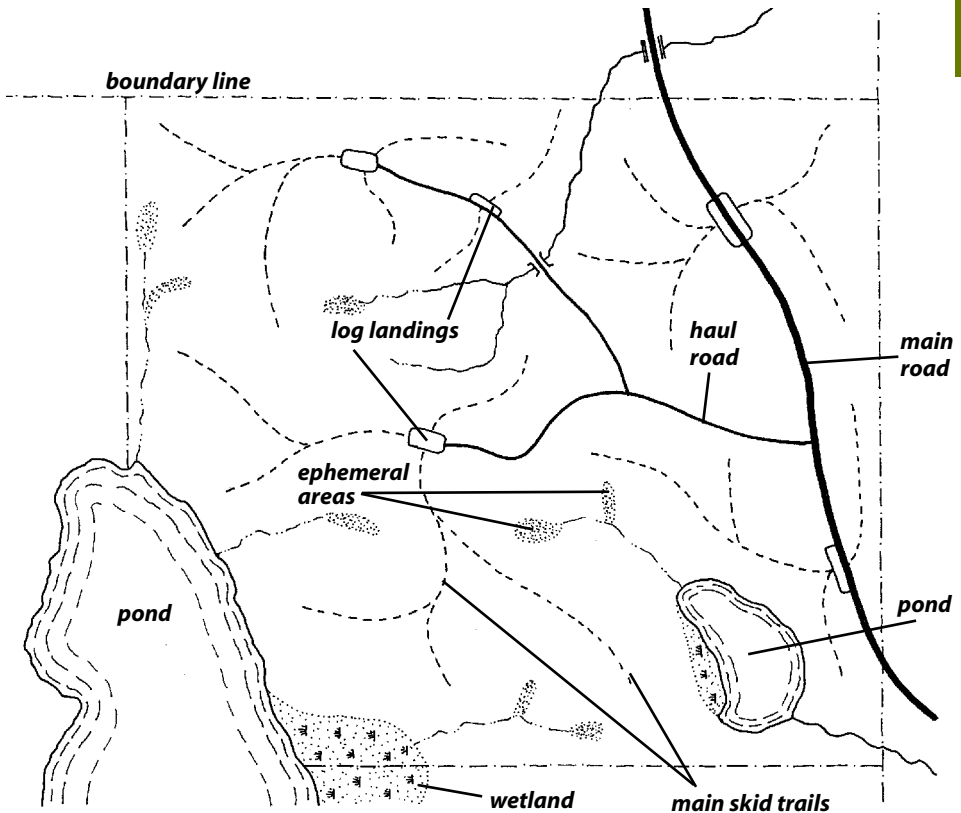

Example of large lot layout.

BUILD IT RIGHT

BMPs

- 1 Construct trails using simple structures that divert water.**
Keeping water out of the trail not only prevents erosion, but also reduces equipment wear and extends the period that the trail is usable (both during and after wet weather).
- 2 If possible, limit the use of equipment in filter areas, or harvest only on frozen ground.**
- 3 Limit the amount of disturbed soil in filter areas and make sure that any sediment is filtered out before it reaches surface water.** This reduces the impact of skidding and forwarding.
- 4 Use brush to reduce the amount of ground compaction the equipment causes, to prevent soil disturbance, and to stabilize areas of exposed soil in filter areas.**



Brush on skid trails, as well as frozen ground, helps minimize soil disturbance and rutting.

KEY ISSUE
Water Diversions FOR TRAILS

BMPs

- 1 Install water bars, skid humps, or other diversions to move water off the trail, preferably before it reaches the filter area.
- 2 Locate waterbars and other diversions frequently enough to prevent water from accumulating, based on Table E. On some sites, choosing appropriate locations for diversions may be more important than their spacing.

Table E
Waterbar Spacing Guidelines

Slope (%)	Spacing (ft)
1-2	250-400
3-5	135-250
6-10	80-135
11-15	60-80
16-20	45-60
21+	<45

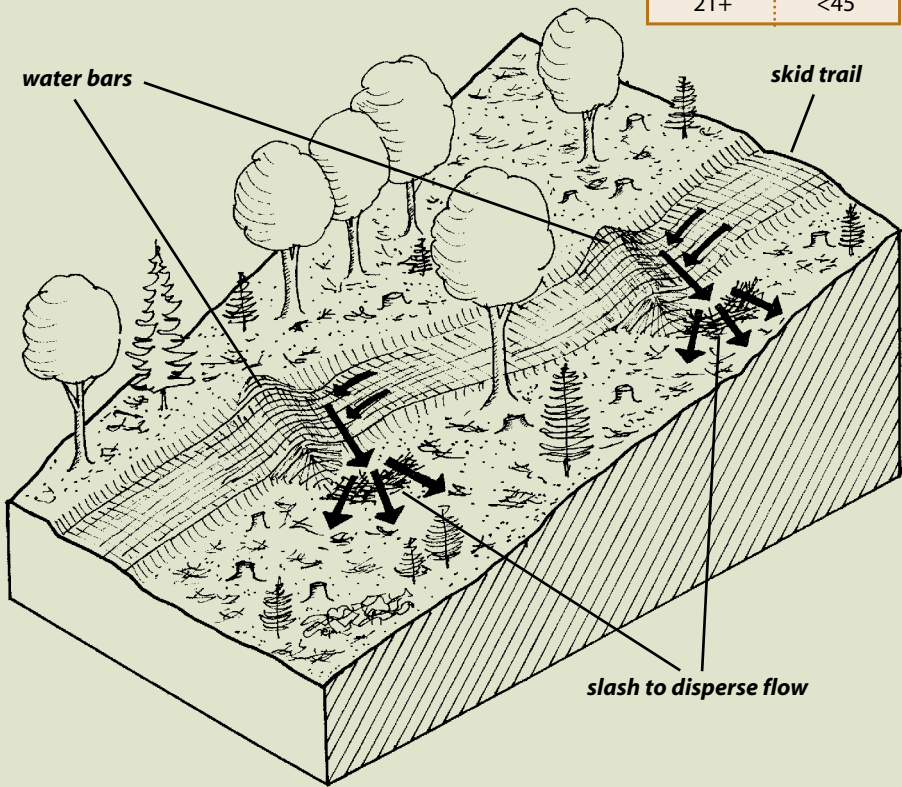

BMPs

- 3 Make waterbars at least 6-12 inches deep, 6-12 inches high, and install them at a 30-degree angle to the trail.
- 4 Extend the water bar inlet and outlet 1 foot or more beyond the trail to keep the diverted water from re-entering the trail.
- 5 Use the terrain to incorporate natural skid humps into the trail layout, to help divert water from the trail.
- 6 Put brush in the trail, as needed, to help disperse water.

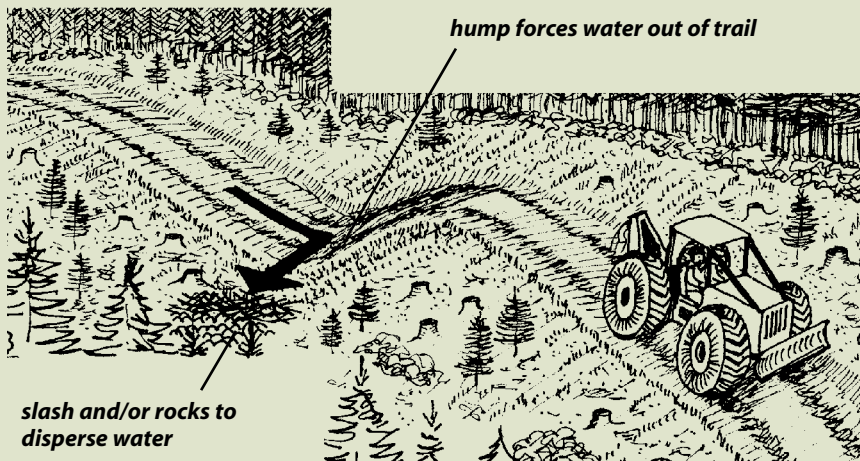

Skid hump.

HARVEST IT RIGHT

Trees and other vegetation are important components of filter areas. One of the most important BMPs for trails is to keep enough trees and other vegetation within the filter area to provide adequate shade, stabilize the banks, limit impacts to soils, and supply organic material to the water.



Harvest restrictions and required practices may apply in some jurisdictions. Call the town office and NHDES Wetlands Bureau 603-271-2147 for information about designated prime wetlands.

BMPs

- 1 Modify the filter area width as needed to achieve the goals mentioned above.**
- 2 Maintain a diverse species composition.**
- 3 Retain a range of both larger- and smaller-diameter trees.**
- 4 Leave an adequate canopy of trees and shrubs to shade the water surface and provide leaf litter.**
- 5 Limit harvesting that removes most of the forest structure (like clearcuts or overstory removal) in filter areas.** Some small patch openings may be appropriate if they maintain or enhance the forest structure.
- 6 In general, harvest less and less intensively as you get nearer to the waterbody, although harvest intensity will vary with local stand conditions.**
- 7 Use directional felling to drop trees away from waterbodies.** Avoid dropping slash or logs into stream channels and other waterbodies or wetlands.
- 8 Remove slash that has fallen into waterbodies with a boom, winch, or by hand.** Leave any tops or stems that have fallen into the water naturally.

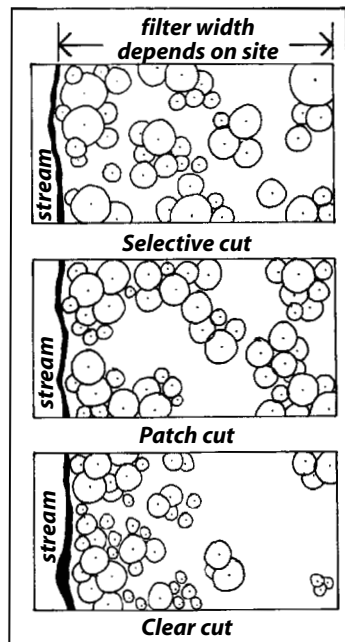

No matter the type of cut, always retain more trees near waterbodies.

MAINTAIN IT

BMPs

- 1 Use brush on main trails and in filter areas to prevent ruts from developing. If ruts develop anyway, stabilize them using more brush and consider relocating to firmer ground, or waiting for drier or frozen conditions.
- 2 Inspect and maintain water bars periodically to prevent water channels from developing in the trails.
- 3 Stay alert to weather forecasts of significant rain or substantial thawing. Consider:
 - limiting equipment use, working in a different area, or doing other work until the site dries up or refreezes;
 - applying brush to soft areas to distribute the equipment's weight before problems develop; and
 - installing additional temporary diversions, especially water bars, to prevent water from running in the trail.



Water bars move water out of the trail onto the forest floor.

CLOSE IT OUT CORRECTLY

Proper closeout ensures that future problems do not develop.

BMPs

- 1 **Identify the long-term monitoring and maintenance needs appropriate to the harvest site and decide who is responsible for them.** Communicate this to the landowner, forester, and logger.



A trail closed-out with water bar and seeding.

BMPs

- 2 **Close out unused trails as the job progresses.**
- 3 **Install diversions such as water bars on trails before leaving a site permanently or suspending operations for more than a few weeks. Diversions should be installed wherever water channels could develop that will carry runoff to waterbodies or their filter areas.**
- 4 **Smooth rutted trails if necessary to keep channels from forming, and to divert runoff directly into filter areas.**



HIGHEST PRIORITIES

- Know how to handle and store hazardous materials.
- Avoid leaks and spills.
- Know how to deal with accidents.

HAZARDOUS MATERIALS

FUELS, OIL, AND COOLANTS

Oils, fuels, hydraulic fluids, coolants, etc. are hazardous materials commonly used at log landings. It is important to know how to handle these materials, how to avoid spills while maintaining or repairing equipment, and how to respond to accidents.

BMPs

- 1 Use appropriate containers for collecting and storing oils, fuels, coolants, or hazardous wastes.** Store these materials in designated areas and remove them from the site when they are no longer needed.
- 2 Maintain and repair all equipment outside of filter areas.** Inspect hoses, fuel trucks, and tanks for leaks, and make repairs immediately.
- 3 Have spill kits or other absorbent materials for mopping up spills readily available.** Hay or sawdust may be adequate for very small spills. Waste containment kits are available commercially and should be on hand for larger spills.
- 4 If a spill occurs, keep it from flowing off the yard and into surface waters.**
- 5 Know what state agency phone numbers to call in case of an emergency.**
- 6 Collect trash and dispose of it properly.**

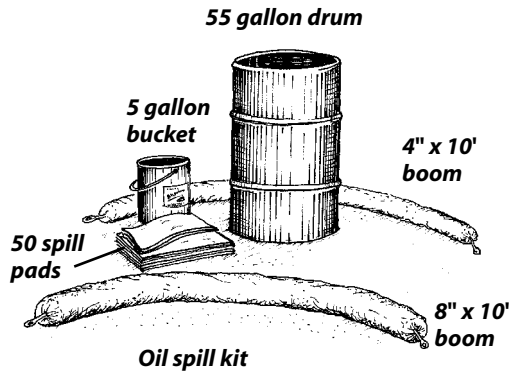

For assistance with spills of hazardous materials, call the New Hampshire Department of Environmental Services:

**Monday – Friday
8:00 a.m. – 4:00 p.m.
(603) 271-3644**

**All other times call:
(603) 271-3636**

TEMPORARY SAND AND SALT STORAGE AREAS

Sand and salt are often necessary to maintain safe winter conditions on truck roads. The following BMPs will help minimize or eliminate the possibility that these materials will discharge from storage areas to waterbodies or into the groundwater.

BMPs

- 1 **Locate sand and salt storage areas away from waterbodies, wetlands, ephemeral flow areas, or other wet areas.**
- 2 **Locate storage areas on high flat ground, near the road, and away from water diversions that direct water into road ditches.**
- 3 **Enclose the storage area with a berm high enough to contain rain and snow that may collect in the storage area.** Put a heavy impermeable liner, such as heavy plastic, on the ground where the sand and salt will be stored. Run the liner up the sides of the berm. The goal is to minimize the amount of moisture reaching the groundwater.
- 4 **Leave at least a 6-inch layer of mixed sand and salt over the liner at all times to avoid puncturing it when digging in the pile.**
- 5 **Cover the sand and salt mixture with heavy plastic when it is not being used.**
- 6 **When abandoning the site, remove the remaining sand and salt mixture and the liner, and properly dispose of them off-site.**
- 7 **Return the site to its original condition.**
If necessary, seed or plant with a vegetative cover.

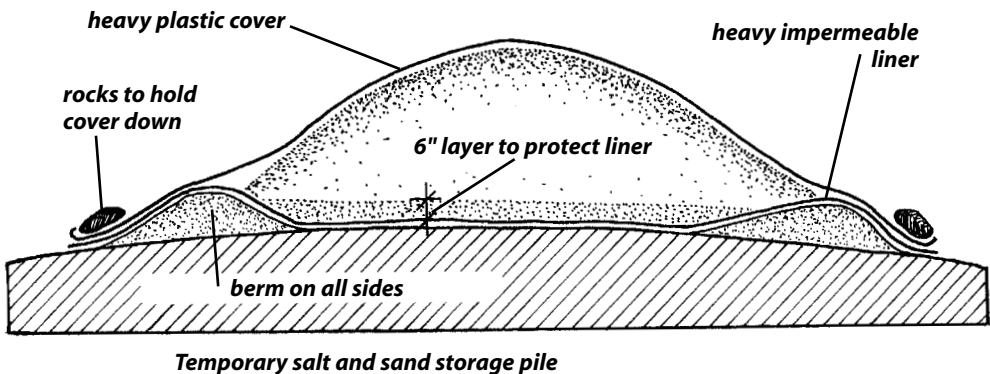

HERBICIDE AND PESTICIDE USE

All herbicides and pesticides are regulated by state law through the NH Dept. of Agriculture, Markets & Food, Division of Pesticide Control at agriculture.nh.gov/about/pesticide_control.htm. Commercial herbicide and pesticide applicators must be licensed or permitted by the Division of Pesticide Control. Landowners or managers who wish to apply herbicides and pesticides themselves on their own land should contact the Division before proceeding.



BMPs

- 1 Maintain the required buffers between spray operations and waterbodies.**
- 2 Apply pesticides and herbicides during favorable weather conditions.**
- 3 Abide by all pesticide label requirements, including use rates, handling, storage, and disposal.**
- 4 All herbicide and pesticide handling—mixing, loading, equipment cleaning, and storage—should be done away from waterbodies, outside filter areas, and away from road drainage systems.**
- 5 Remove stored chemicals from the site when they are no longer needed.**
- 6 Have spill kits or other absorbent materials on hand for mopping up spills.**

FOR MORE INFORMATION

SOURCES OF TECHNICAL ASSISTANCE

NH Division of Forests and Lands

NH Department of Resources and Economic Development,
Forest Protection Bureau & Natural Heritage Bureau
PO Box 1856, 172 Pembroke Rd.
Concord, NH 03302-1856
(603) 271-2217
<http://www.nhdf.org>

NH Wetlands Bureau

NH Department of Environmental Services
PO Box 95, 29 Hazen Drive
Concord, NH 03302-0095
(603) 271-2147
<http://www.des.nh.gov/wetlands>

NH Inland Fisheries Division

NH Fish and Game Department
11 Hazen Drive
Concord, NH 03301
(603) 271-2501
<http://wildlife.state.nh.us>

UNH Cooperative Extension, Forestry & Wildlife Program

214 Nesmith Hall, 131 Main Street
Durham, NH 03824
(603) 862-1028
<http://ceinfo.unh.edu> (Forestry & Wildlife Resources)

USDA, Natural Resources Conservation Service

Federal Building, 2 Madbury Road
Durham, NH 03824-2043
(603) 868-7581
www.nh.nrcs.usda.gov

REFERENCES

- Calhoun, A.J.K. and P. deMaynadier 2004. "Forestry Habitat Management Guidelines for Vernal Pool Wildlife in the Northeast." PARC (Partners in Amphibian & Reptile Conservation) www.parcplace.org
- Hodgkins, G. "Estimating the Magnitude of Peak Flows for Streams in Maine for Selected Recurrence Intervals." Water Resources Investigations Report 99-4008. U.S. Geological Survey, 1999.
- Kennebec County Soil and Water Conservation District and the Maine Department of Environmental Protection. *Camp Road Maintenance Manual: A Guide for Landowners*. 2000.
- United States Department of Agriculture, Soil Conservation Service. Computer Program for Project Formulation—Hydrology, Technical Release #20 (TR-20). 1983.
- United States Department of Agriculture, Soil Conservation Service. "Urban Hydrology for Small Watersheds," Technical Release #55 (TR-55). June, 1986.
- Verry, E.S.; J.W. Hornbeck; and C.A. Dolloff (eds.) *Riparian Management in Forests of the Continental Eastern United States*. Boca Raton: Lewis Publishers, 2000.
- Welsch, D.J.; D.L. Smart; J.N. Boyer; P. Minkin; H.C. Smith; and T.L. McCandless. *Forested Wetlands: Functions, Benefits, and the Use of Best Management Practices*. USDA Forest Service publication NA-PR-001-95, 1995.
- Wiest, R.L. *A Landowner's Guide to Building Forest Access Roads*. USDA Forest Service publication NA-TP-06-98. 1998.

Online:

- *Massachusetts River and Stream Crossing Standards: Technical Guidelines*. August 6, 2004.
www.umass.edu/nrec/pdf_files/guidelines_river_stream_crossings.pdf
www.umass.edu/nrec/onlinedocs.html
- *NH Department of Environmental Services – Wetlands Rules and Law*.
<http://des.nh.gov/wetlands/rule-law.htm>
- *Guide to NH Timber Harvesting Laws*. (2004)
<http://ceinfo.unh.edu/Pubs/ForPubs/gtnhthl.pdf>

The University of New Hampshire Cooperative Extension is an equal opportunity educator and employer. UNH, U.S. Dept. of Agriculture and New Hampshire counties cooperating.



UNIVERSITY *of* NEW HAMPSHIRE
COOPERATIVE EXTENSION

2005